

Cooling/Heating Comfort Systems

Technical Guide for:

- **IFL** High Efficiency, High Turndown, High Filtration Comfort Systems

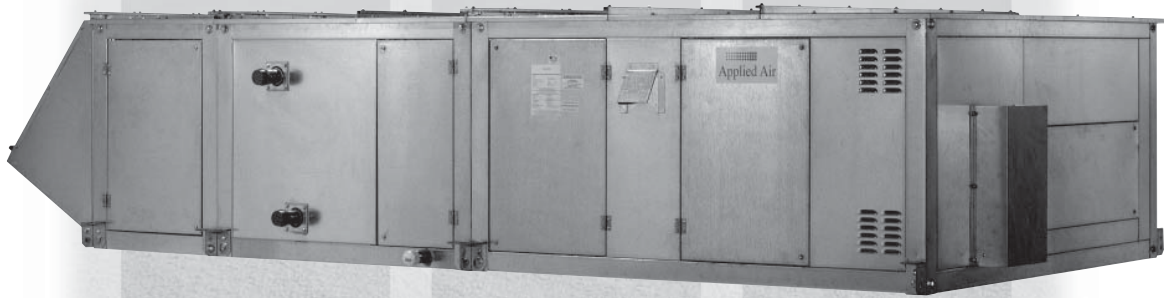

Applied Air

Keeps You

Comfortable



Applied Air



• **Cooling/Heating**
• **Comfort Systems**
• **Technical Guide**
•
•
•
•
•
•
•
•



Applied Air

In the business of industrial heating, efficient and low-cost operation is essential. Applied Air keeps you warm for less.

Since 1975, Applied Air has been providing cost-effective, reliable heating solutions. Our proven Indirect Fired Heating Systems adds warm clean air to your work environment, but without the products of combustion in the airstream.

This Technical Guide will help you choose an Applied Air Cooling/Heating Comfort System to provide efficient, cost-effective cooling, heating and ventilation for your facility. The Guide covers:

- Technical Specifications — Configure the right system components (e.g., motors, drive, filter, options, etc.) to meet your needs.
- Installation Information — Plan details of on-site installation (dimensions, gas piping, etc.).

If you have questions, please contact Applied Air's Customer Service Department at 214-638-6010. We'll be glad to help.

Applied Air

Keeps You

Comfortable



Applied Air

- Engineering Data 4
- Pressure Drop Data
 - Heat Exchanger 5
 - Inlet Hood..... 5
 - Filters 6
- Coil Performance Data
 - 4 Row DX with R410 7
 - 6 Row DX with R410 8
 - 8 Row DX with R410 9
 - 4 Row CW 10
 - 6 Row CW 11
 - 8 Row CW 12
- Air Delivery Tables
 - IFL-20 13
 - IFL-40 14
 - IFL-60 15
- Dimensional Data 16
- Roof Curb 17
- Gas Piping Layout 17
- Control Systems 18 - 21
- Typical Wiring 22, 23
- Amp Draw Table 24
- Unit Weights 25
- Guide Specification 26, 27

Engineering Data – IFL Series

Capacity and Internal Data			Model Size		
			20	40	60
SIZE and CAPACITY	Cooling	DX (See Note A)	421,800	786,335	1,192,359
		CW (See Note B)	425,958	795,348	1,129,257
	Gas Heating	Input BTU/Hr (Maximum)	200,000	400,000	600,000
		Output BTU/Hr (D)	160,000	320,000	480,000
		Minimum Operating Efficiency at Maximum Input	82%	81%	80%
		Input BTU/Hr (Minimum)	6,000	6,000	6,000
		Maximum Operating Efficiency at Minimum Input	88%	88%	88%
Burner Turndown Ratio	33:1	67:1	100:1		
FIRING RATE and MANIFOLD SIZE	Natural Gas at 1,000 BTU/C.F.	200	400	600	
	Natural Gas Std Pipe Size (7" W.C.)	3/4"	3/4"	1"	
	Manifold Pressure	3.0	3.0	3.6	
SUPPLY AIR CAPACITY	Minimum Airflow	1500	3000	4500	
	Maximum Airflow	5000	9500	14,000	
COMBUSTION AIR and VENTING REQUIREMENTS	Combustion Air Requirements (CFM)	39	77	115	
	Recommended Minimum Stack Diameter	4"	6"	7"	
	Maximum Vent Length - Equivalent Length (Ft)	50	50	50	
INTERNAL DATA of HEAT EXCHANGER (C)	Primary Heating Surface	- Sq. Ft.	13.49	21.35	32.97
	Secondary Heating Surface (Tubes and Headers)	- Sq. Ft.	16.23	27.87	45.75
	Primary Combustion Volume	- Cu. Ft.	3.47	6.94	12.73
	Secondary Combustion Volume	- Cu. Ft.	0.93	1.74	2.76
	Total Combustion Volume	- Cu. Ft.	4.40	8.68	15.49

NOTES:

- (A) Capacities based on R410 8 Row, 8 FPI (two circuit) DX coil with 45° suction temperature and 95°/77° entering air temperature.
- (B) Capacities based on 8 Row, 8 FPI CW coil with 45° Entering Water Temperature, 55° Leaving Water Temperature and 95°/77° entering air temperature.
- (C) Standard Construction - 400 Series stainless steel primary and secondary material.
- (D) Based on 80% operating efficiency.

Pressure Drop Data – Heat Exchanger and Inlet Hood

Table 1

Model	Furnace Size	CFM	Pressure Drop (Inches W.C.)		
			Heat Exchanger	Inlet Hood Without Filters	Inlet Hood With 2" Perm Filters
20	160	1500	0.09	0.014	0.036
		2000	0.17	0.024	0.065
		2500	0.27	0.038	0.101
		3000	0.40	0.055	0.145
		3500	0.55	0.075	0.198
		4000	0.70	0.098	0.258
		4500	0.89	0.124	0.327
		5000	1.10	0.153	0.403
40	160	3000	0.40	0.016	0.024
		3500	0.55	0.021	0.032
		4000	0.70	0.028	0.042
		4500	0.89	0.035	0.054
		5000	1.10	0.044	0.066
	320	3000	0.25	0.016	0.024
		3500	0.32	0.021	0.032
		4000	0.41	0.028	0.042
		4500	0.41	0.035	0.054
		5000	0.50	0.044	0.066
		5500	0.59	0.053	0.080
		6000	0.71	0.063	0.095
		6500	0.65	0.074	0.112
		7000	0.74	0.086	0.130
		7500	0.85	0.098	0.149
		8000	0.95	0.112	0.170
		8500	1.07	0.126	0.191
		9000	1.18	0.142	0.215
9500	1.32	0.158	0.239		
60	320	4500	0.41	0.011	0.015
		5000	0.50	0.014	0.018
		5500	0.59	0.017	0.022
		6000	0.71	0.020	0.026
		6500	0.65	0.023	0.031
		7000	0.74	0.027	0.036
		7500	0.85	0.031	0.041
		8000	0.95	0.036	0.047
		8500	1.07	0.040	0.053
		9000	1.18	0.045	0.059
	480	9500	1.32	0.050	0.066
		4500	0.24	0.011	0.015
		5000	0.29	0.014	0.018
		5500	0.35	0.017	0.022
		6000	0.41	0.020	0.026
		6500	0.47	0.023	0.031
		7000	0.53	0.027	0.036
		7500	0.59	0.031	0.041
		8000	0.66	0.036	0.047
		8500	0.73	0.040	0.053
		9000	0.80	0.045	0.059
		9500	0.87	0.050	0.066
		10,000	0.95	0.056	0.073
		10,500	0.76	0.061	0.081
		11,000	0.81	0.067	0.089
		11,500	0.87	0.073	0.097
		12,000	0.92	0.080	0.106
		12,500	0.98	0.087	0.115
13,000	1.04	0.094	0.124		
13,500	1.09	0.101	0.134		
14,000	1.15	0.109	0.144		

Air Pressure Drop For Optional Accessories:

Horsepower selections are based on total system static pressure. One or more of the following must be added when applicable:

- | | |
|-------------------------------|------------------|
| A. Heat Exchanger | See Table 1 |
| B. Inlet Hood with Birdscreen | See Table 1 |
| C. Inlet Hood with Filters | See Table 1 (1) |
| D. Inlet Shut-Off Damper | 0.13" W.C. |
| E. Mixing Dampers | 0.13" W.C. |
| F. Filter Section | See Table 2 |
| G. Coil Section | See Pages 7 - 12 |

Note:

- Filter quantity and size in Inlet Hood:
Size 20 - 3) 20" x 24"
Size 40 - 6) 20" x 24"
Size 60 - 18) 15" x 20"

Example:

Select a system for 8,000 CFM of supply air with 2.0" duct static requiring 480 MBH output and inlet hood without filters, inlet damper, and 4 row DX cooling coil section with 2" pleated filters.

- From Engineering Data chart on page 4, we see that IFL-40 or IFL-60 will provide 8,000 CFM but only the IFL-60 can offer the 480 MBH output.
- Go to Table 1 for IFL-60 with 480 MBH heater to find Heat Exchanger and Inlet Hood Pressure Drop for 8000 CFM.
Heat Exchanger P.D. = 0.66" W.C.
Inlet Hood without Filters = 0.036" W.C.
- From chart above showing Air Pressure Drop for Optional Accessories we find loss for Inlet Damper.
Inlet Damper = 0.13" W.C.
- Go to Table 2 on page 6 for IFL-60 to find Pressure Drop for 8000 CFM with 2" Pleated filters on cooling coil section.
2" Pleated Filters = 0.119" W.C.
- Go to Cooling Coil tables for 4 Row DX coil on page 7 for IFL-60 to find Pressure Drop for 8000 CFM.
4 Row DX coil = 0.35" W.C.
- Add pressure drops from steps 2 through 5 to system duct static.

Duct Static	=	2.00" W.C.
Heat Exchanger Pressure Drop	=	0.66" W.C.
Inlet Hood	=	0.036" W.C.
Inlet Damper	=	0.13" W.C.
2" Pleated Filter	=	0.119" W.C.
4 Row DX Coil	=	0.35" W.C.
Total Static Pressure	=	3.295" W.C.
- Enter fan chart for IFL-60 on page 15 for 8000 CFM and 3.50" TSP to find that 7½ HP motor is required.

Filter Resistance

Resistance of Clean Filters in Inches of W.C.

Table 2

Model	CFM	2" Flat Filter Section Cooling Coil Section (3)			2" Flat Filter Section (4)					4" High Efficiency Filter Section (4)				12" High Efficiency Filter Section (4)		
		Face		MERV 8 Pleated	Face		MERV 5 TAW	MERV 8 Pleated	Perm	Face		MERV 11 60-65%	MERV 15 90-95%	Face		MERV 14 90-95%
		Area (Sq. Ft.)	Velocity FPM		Area (Sq. Ft.)	Velocity FPM				Area (Sq. Ft.)	Velocity FPM			Area (Sq. Ft.)	Velocity FPM	
20	1500	11.1	135	0.030	12.0	125	0.022	0.026	0.022	12.0	125	0.062	0.090	12.0	125	0.087
	2000		180	0.053		167	0.040	0.047	0.039		167	0.110	0.159		167	0.155
	2500		225	0.083		208	0.062	0.073	0.061		208	0.173	0.249		208	0.243
	3000		270	0.119		250	0.089	0.106	0.088		250	0.248	0.359		250	0.350
	3500		315	0.162		292	0.121	0.144	0.119		292	0.338	0.488		292	0.476
	4000		360	0.212		333	0.159	0.188	0.156		333	0.442	0.637		333	0.621
	4500		405	0.268		375	0.201	0.238	0.197		375	0.559	0.807		375	0.787
	5000		450	0.331		417	0.248	0.293	0.244		417	0.690	0.996		417	0.971
40	3000	18.0	167	0.046	20.0	150	0.028	0.037	0.026	20.0	150	0.085	0.118	20.0	150	0.109
	3500		194	0.062		175	0.039	0.050	0.036		175	0.115	0.160		175	0.148
	4000		222	0.081		200	0.050	0.066	0.046		200	0.150	0.210		200	0.194
	4500		250	0.103		225	0.064	0.083	0.059		225	0.190	0.265		225	0.245
	5000		278	0.127		250	0.079	0.103	0.073		250	0.235	0.328		250	0.303
	5500		306	0.153		275	0.095	0.124	0.088		275	0.284	0.396		275	0.366
	6000		333	0.182		300	0.113	0.148	0.104		300	0.338	0.472		300	0.436
	6500		361	0.214		325	0.133	0.173	0.123		325	0.397	0.553		325	0.511
	7000		389	0.248		350	0.154	0.201	0.142		350	0.461	0.642		350	0.593
	7500		417	0.285		375	0.177	0.231	0.163		375	0.529	0.737		375	0.681
	8000		444	0.324		400	0.202	0.262	0.186		400	0.602	0.838		400	0.774
	8500		472	0.366		425	0.228	0.296	0.210		425	0.679	0.946		425	0.874
	9000		500	0.410		450	0.255	0.332	0.235		450	0.761	1.061		450	0.980
	9500		528	0.457		475	0.284	0.370	0.262		475	0.848	1.182		475	1.092
60	4500	28.9	156	0.038	29.3	154	0.029	0.038	0.027	29.3	154	0.088	0.122	29.3	154	0.110
	5000		173	0.047		171	0.036	0.047	0.033		171	0.108	0.150		171	0.136
	5500		190	0.056		188	0.044	0.056	0.040		188	0.131	0.182		188	0.165
	6000		208	0.067		205	0.052	0.067	0.048		205	0.155	0.216		205	0.196
	6500		225	0.079		222	0.061	0.079	0.056		222	0.182	0.253		222	0.230
	7000		242	0.091		239	0.071	0.091	0.065		239	0.211	0.293		239	0.266
	7500		260	0.105		256	0.081	0.104	0.075		256	0.242	0.337		256	0.305
	8000		277	0.119		273	0.092	0.119	0.085		273	0.276	0.383		273	0.347
	8500		294	0.135		290	0.104	0.134	0.096		290	0.311	0.432		290	0.392
	9000		311	0.151		307	0.117	0.150	0.108		307	0.349	0.484		307	0.439
	9500		329	0.168		324	0.130	0.167	0.120		324	0.388	0.539		324	0.489
	10,000		346	0.186		341	0.144	0.185	0.133		341	0.430	0.597		341	0.542
	10,500		363	0.205		358	0.159	0.204	0.146		358	0.474	0.658		358	0.597
	11,000		381	0.225		375	0.174	0.224	0.160		375	0.520	0.722		375	0.655
	11,500		398	0.246		392	0.190	0.245	0.175		392	0.568	0.789		392	0.716
	12,000		415	0.268		410	0.208	0.268	0.192		410	0.622	0.863		410	0.783
12,500	433	0.291	427	0.226	0.290	0.208	427	0.675	0.936	427	0.849					
13,000	450	0.315	444	0.244	0.314	0.225	444	0.729	1.012	444	0.918					
13,500	467	0.339	461	0.263	0.339	0.243	461	0.786	1.091	461	0.990					
14,000	484	0.365	478	0.283	0.364	0.261	478	0.845	1.173	478	1.064					

NOTES:

1. Recommended maximum dirty filter resistance: 2" Filters - 0.50" W.C. 4" Filters - 1.50" W.C. 12" Filters - 1.50" W.C.
2. System design may require lower filter changeout point.
3. Filter quantity and size in Cooling Coil Sections:
 Size 20 - 4) 16" x 25"
 Size 40 - 4) 20" x 20" and 2) 20" x 25"
 Size 60 - 4) 16" x 20" and 8) 18" x 20"
4. Filter quantity and size in Flat Bank Filter Sections:
 Size 20 - 3) 24" x 24"
 Size 40 - 6) 20" x 24"
 Size 60 - 4) 20" x 24" and 4) 24" x 24"

4 Row DX with R410

MODEL	Coil Face Area FH x FL	CFM	Face Velocity (FPM)	4 Row DX			
				Total MBH	LAT	Air P.D.	Weight (LBS)
20	24 x 36	1,500	250	110.86	57.5/56.1	0.19	81
		2,000	333	137.59	59.8/58.0	0.29	
		2,500	417	160.61	61.8/59.4	0.41	
		3,000	500	173.17	64.1/61.6	0.55	
	24 x 63	3,500	333	242.41	59.8/58.1	0.29	132
		4,000	381	266.71	61.0/58.8	0.36	
4,500		429	288.53	61.8/59.5	0.43		
40	30 x 44	3,000	327	201.17	60.6/58.5	0.28	115
		3,500	382	225.04	61.4/59.3	0.36	
		4,000	436	247.42	62.6/60.2	0.44	
		4,500	491	269.41	63.8/61.0	0.54	
	36 x 56	5,000	357	334.60	60.6/58.5	0.32	165
		5,500	393	360.08	61.4/59.1	0.37	
		6,000	429	382.94	62.2/59.7	0.43	
		6,500	464	403.16	62.6/60.2	0.49	
		7,000	500	424.03	63.0/60.6	0.55	
	40.5 x 63	7,500	424	471.39	62.2/59.7	0.42	202
		8,000	452	494.16	62.6/60.2	0.47	
		8,500	480	515.96	63.0/60.6	0.52	
9,000		508	537.29	63.8/61.0	0.57		
9,500		537	557.87	64.1/61.5	0.62		
60	42 x 48	4,500	321	306.80	60.2/58.3	0.27	164
		5,000	357	331.33	61.0/58.8	0.32	
		5,500	393	353.73	61.4/59.3	0.37	
		6,000	429	376.64	62.2/59.9	0.43	
		6,500	464	399.79	63.0/60.6	0.49	
		7,000	500	419.03	63.8/60.9	0.55	
	45 x 68	7,500	353	512.09	60.2/58.3	0.32	237
		8,000	376	533.19	60.6/58.5	0.35	
		8,500	400	558.54	61.4/59.0	0.39	
		9,000	424	579.23	61.4/59.2	0.42	
		9,500	447	601.63	62.2/59.7	0.46	
		10,000	471	624.08	62.6/60.1	0.50	
	51 x 80	10,500	494	643.68	63.0/60.4	0.54	307
		11,000	388	731.39	60.6/58.8	0.37	
		11,500	406	753.97	61.4/59.0	0.39	
		12,000	424	773.95	61.4/59.2	0.42	
		12,500	441	797.85	62.2/59.6	0.45	
		13,000	459	820.74	62.2/60.0	0.48	
51 x 80	13,500	477	839.55	62.6/60.2	0.51	307	
	14,000	494	862.93	63.0/60.5	0.54		

1. Nominal cooling capacity based on a 4 row / 8 FPI two circuit DX coil with 45°F suction temperature and 95° / 77° entering air temperature.
2. Ask your local representative for a computer print out showing coil performance for conditions different than those shown above.
3. Coil weight is for 4 row / 8 FPI dry coil. This weight must be added to coil section weight shown on page 25.

6 Row DX with R410

MODEL	Coil Face Area FH x FL	CFM	Face Velocity (FPM)	6 Row DX				
				Total MBH	LAT	Air P.D.	Weight (LBS)	
20	24 x 36	1,500	250	130.72	51.6/51.4	0.28	115	
		2,000	333	162.90	54.4/53.8	0.44		
		2,500	417	194.07	55.2/54.9	0.62		
		3,000	500	223.76	56.7/56.1	0.83		
	24 x 63	3,500	333	288.05	53.6/53.3	0.44	188	
		4,000	381	321.49	54.4/54.1	0.54		
4,500		429	351.56	55.2/54.7	0.65			
40	30 x 44	5,000	476	379.18	55.9/55.3	0.76	165	
		3,000	327	246.55	53.6/53.0	0.42		
		3,500	382	280.85	54.4/54.1	0.54		
		4,000	436	311.95	55.5/55.0	0.66		
	36 x 56	4,500	491	339.92	56.3/55.7	0.80	238	
		5,000	357	399.73	54.4/53.8	0.48		
		5,500	393	434.08	55.2/54.5	0.56		
		6,000	429	462.54	55.5/55.0	0.65		
		6,500	464	494.50	55.9/55.5	0.73		
		7,000	500	525.93	56.7/56.1	0.83		
	40.5 x 63	7,500	424	588.40	55.2/54.6	0.63	294	
		8,000	452	618.04	55.5/54.9	0.70		
		8,500	480	647.96	55.9/55.3	0.77		
		9,000	508	677.30	56.7/55.7	0.85		
		9,500	537	703.97	56.7/56.1	0.93		
		60	42 x 48	4,500	321	376.14		53.6/53.0
	5,000			357	405.61	53.6/53.4	0.48	
	5,500			393	439.91	54.4/54.1	0.56	
6,000	429			469.05	55.2/54.7	0.65		
6,500	464			500.85	55.9/55.3	0.73		
7,000	500			527.48	56.3/55.7	0.83		
45 x 68	7,500		353	615.13	53.6/53.3	0.48	345	
	8,000		376	632.85	55.2/54.5	0.53		
	8,500		400	662.97	55.2/54.8	0.58		
	9,000		424	692.17	55.5/55.0	0.63		
	9,500		447	720.76	55.9/55.4	0.69		
	10,000		471	752.37	56.3/55.7	0.75		
51 x 80	10,500		494	780.15	56.7/56.1	0.81	447	
	11,000		388	873.50	54.4/54.1	0.55		
	11,500		406	908.36	55.2/54.5	0.59		
	12,000		424	938.13	55.2/54.8	0.63		
	12,500		441	964.64	55.5/55.0	0.68		
	13,000		459	1000.27	55.9/55.3	0.72		
	13,500		477	1028.23	55.9/55.5	0.77		
	14,000		494	1054.84	56.3/55.7	0.81		

1. Nominal cooling capacity based on a 6 row / 8 FPI two circuit DX coil with 45°F suction temperature and 95° / 77° entering air temperature.
2. Ask your local representative for a computer print out showing coil performance for conditions different than those shown above.
3. Coil weight is for 6 row / 8 FPI dry coil. This weight must be added to coil section weight shown on page 25.

8 Row DX with R410

MODEL	Coil Face Area FH x FL	CFM	Face Velocity (FPM)	8 Row DX			
				Total MBH	LAT	Air P.D.	Weight (LBS)
20	24 x 36	1,500	250	138.30	48.9/48.9	0.38	150
		2,000	333	179.82	50.1/50.1	0.58	
		2,500	417	218.36	51.3/51.3	0.82	
		3,000	500	253.00	52.8/52.5	1.10	
	24 x 63	3,500	333	312.22	50.5/50.4	0.58	245
		4,000	381	351.34	51.3/51.0	0.71	
4,500		429	387.59	51.3/51.3	0.86		
5,000		476	421.80	52.0/52.0	1.02		
40	30 x 44	3,000	327	272.45	49.7/49.7	0.56	215
		3,500	382	305.36	51.3/51.2	0.72	
		4,000	436	340.75	52.0/51.8	0.89	
		4,500	491	376.66	52.8/52.5	1.07	
	36 x 56	5,000	357	445.83	50.5/50.4	0.65	312
		5,500	393	483.54	50.9/50.9	0.75	
		6,000	429	512.91	52.0/51.8	0.86	
		6,500	464	550.62	52.0/52.0	0.98	
	40.5 x 63	7,000	500	586.42	52.8/52.8	1.10	385
		7,500	424	647.66	51.3/51.3	0.84	
		8,000	452	685.97	52.0/51.9	0.94	
		8,500	480	719.97	52.0/52.0	1.03	
60	42 x 48	9,000	508	750.11	52.8/52.5	1.13	312
		9,500	537	786.34	52.8/52.8	1.24	
		4,500	321	409.18	49.7/49.7	0.55	
		5,000	357	444.12	50.5/50.5	0.65	
		5,500	393	478.14	51.3/51.1	0.75	
		6,000	429	516.51	51.3/51.3	0.86	
	45 x 68	6,500	464	556.41	52.0/52.0	0.98	453
		7,000	500	587.81	52.8/52.5	1.10	
		7,500	353	667.84	50.5/50.5	0.63	
		8,000	376	708.04	50.5/50.5	0.70	
		8,500	400	741.14	51.3/51.1	0.77	
		9,000	424	780.53	51.3/51.3	0.84	
51 x 80	9,500	447	816.19	52.0/51.7	0.92	588	
	10,000	471	855.46	52.0/52.0	1.00		
	10,500	494	888.45	52.0/52.0	1.08		
	11,000	388	973.69	50.5/50.5	0.74		
	11,500	406	1016.64	51.3/51.1	0.79		
	12,000	424	1049.95	51.3/51.2	0.84		
51 x 80	12,500	441	1085.43	51.3/51.3	0.90	588	
	13,000	459	1125.39	52.0/51.7	0.96		
	13,500	477	1159.49	52.0/51.9	1.02		
	14,000	494	1192.36	52.0/52.0	1.08		

1. Nominal cooling capacity based on a 8 row / 8 FPI two circuit DX coil with 45°F suction temperature and 95° / 77° entering air temperature.
2. Ask your local representative for a computer print out showing coil performance for conditions different than those shown above.
3. Coil weight is for 8 row / 8 FPI dry coil. This weight must be added to coil section weight shown on page 25.

Coil Performance Data

4 Row CW											
Model	Coil Face Area FH x FL	CFM	Face Velocity (FPM)	4 Row CW					WEIGHT (LBS)		
				Total MBH ⁽¹⁾	LAT	Air P.D.	GPM	FPD (ft)			
20	24 x 36	1500	250	107.32	57.1/56.8	0.19	20.5	3.4	81		
		2000	333	133.23	59.1/58.6	0.29	25.4	5.1			
		2500	417	156.06	60.6/59.8	0.41	29.8	6.9			
		3000	500	177.43	61.8/60.9	0.55	33.9	7.3			
	24 x 63	3500	333	226.20	59.8/59.3	0.29	43.0	3.2	132		
		4000	381	249.41	60.6/59.9	0.35	47.7	3.9			
		4500	429	271.10	61.4/60.6	0.43	51.8	3.7			
		5000	476	290.99	62.2/61.2	0.50	55.3	4.1			
40	30 x 44	3000	327	207.60	58.1/57.7	0.28	39.6	7.5	115		
		3500	382	232.29	59.1/58.6	0.36	44.0	9.1			
		4000	436	256.97	59.8/59.4	0.44	49.0	11.1			
		4500	491	277.72	61.0/60.1	0.53	53.1	11.9			
	36 x 56	5000	357	308.98	60.6/60.2	0.32	59.0	2.5	165		
		5500	393	330.62	61.4/60.6	0.37	63.0	2.9			
		6000	429	351.55	61.8/61.1	0.42	67.2	3.2			
		6500	464	370.74	62.6/61.6	0.48	70.6	3.5			
		7000	500	389.39	63.0/62.0	0.54	74.0	3.8			
		7500	424	453.30	61.4/60.5	0.42	86.7	3.8			
	40.5 x 63	8000	452	474.55	61.8/60.9	0.46	90.7	4.2	203		
		8500	480	494.29	62.2/61.2	0.51	94.0	4.5			
		9000	508	513.84	62.6/61.6	0.56	98.0	4.8			
		9500	537	532.03	63.0/61.9	0.61	101.0	5.1			
		42 x 48	4500	321	275.40	60.8/60.4	0.27	52.5		1.6	165
			5000	357	297.09	61.4/60.9	0.32	56.5		1.8	
5500	393		317.43	62.2/61.4	0.37	60.6	2.1				
6000	429		337.34	62.6/61.8	0.42	64.4	2.3				
6500	464		356.14	63.0/62.3	0.48	68.0	2.6				
7000	500		373.40	63.8/62.8	0.54	71.0	2.8				
45 x 68	7500		353	484.09	59.8/59.3	0.32	92.0	3.8	238		
	8000		376	508.28	60.2/59.5	0.35	97.0	4.2			
	8500	400	530.22	60.6/59.9	0.38	101.0	4.6				
	9000	424	552.31	61.0/60.2	0.42	105.0	4.9				
	9500	447	572.93	61.4/60.5	0.46	109.0	5.3				
	10,000	471	594.29	61.8/60.8	0.49	113.0	5.6				
	10,500	494	614.86	61.8/61.1	0.54	117.0	6.0				
51 x 80	11,000	388	712.73	59.8/59.1	0.37	135.0	7.2	308			
	11,500	406	736.26	59.8/59.4	0.39	140.0	7.7				
	12,000	424	760.31	60.2/59.7	0.42	145.0	8.2				
	12,500	441	779.98	60.6/59.9	0.45	148.0	8.6				
	13,000	459	802.25	61.0/60.1	0.48	152.0	9.0				
	13,500	477	823.51	61.0/60.3	0.51	156.0	9.4				
	14,000	494	847.65	61.4/60.5	0.54	162.0	10.1				

1. Nominal cooling capacity based on a 4 row/ 8 FPI chilled water coil with 45°F EWT, 55°F LWT and 95° / 77° entering air temperature.
2. Ask your local representative for a computer print out showing coil performance for conditions different than those shown above.
3. Coil weight is for 4 Row/ 8 FPI dry coil. This weight must be added to coil section weight shown on page 25.

Coil Performance Data

6 Row CW									
Model	Coil Face Area FH x FL	CFM	Face Velocity (FPM)	6 Row CW					
				Total MBH ⁽¹⁾	LAT	Air P.D.	GPM	FPD (ft)	WEIGHT (LBS)
20	24 x 36	1500	250	122.97	52.8/52.8	0.28	23.5	2.7	116
		2000	333	155.72	54.4/54.4	0.43	29.5	4.1	
		2500	417	186.33	55.5/55.5	0.61	35.5	4.2	
		3000	500	215.00	56.7/56.7	0.82	41.0	5.5	
	24 x 63	3500	333	284.16	53.2/53.2	0.43	54.3	5.5	189
		4000	381	315.71	54.0/54.0	0.53	60.3	6.7	
		4500	429	347.42	54.8/54.8	0.64	66.4	7.9	
		5000	476	377.20	55.2/55.2	0.76	72.0	9.2	
40	30 x 44	3000	327	241.95	53.2/53.2	0.42	46.0	5.4	165
		3500	382	273.49	54.4/54.4	0.54	52.0	5.8	
		4000	436	304.41	55.2/55.2	0.66	58.0	7.1	
		4500	491	333.25	55.9/55.9	0.80	63.3	8.3	
	36 x 56	5000	357	393.59	54.0/54.0	0.48	75.0	5.1	239
		5500	393	424.74	54.8/54.8	0.56	81.0	5.1	
		6000	429	454.10	55.2/55.2	0.64	86.0	5.7	
		6500	464	484.82	55.5/55.5	0.73	92.0	6.5	
		7000	500	513.89	55.9/55.9	0.82	98.0	7.3	
		7500	424	578.92	54.8/54.8	0.63	110.0	8.0	
	40.5 x 63	8000	452	609.42	55.2/55.1	0.70	116.0	8.9	294
		8500	480	640.04	55.4/55.4	0.77	122.0	9.7	
		9000	508	669.49	55.5/55.5	0.84	128.0	10.6	
		9500	537	698.15	55.9/55.9	0.92	133.0	11.4	
		10000	566	727.00	56.2/56.2	1.00	138.0	12.3	
	60	42 x 48	4500	321	368.04	52.8/52.8	0.41	70.0	6.3
5000			357	400.96	53.6/53.6	0.48	76.0	7.3	
5500			393	431.53	54.0/54.0	0.56	82.0	7.6	
6000			429	463.07	54.8/54.8	0.64	88.0	8.6	
6500			464	493.32	55.2/55.2	0.73	94.0	9.7	
7000			500	522.43	55.5/55.5	0.82	99.0	10.7	
45 x 68		7500	353	572.76	54.8/54.8	0.47	109.0	3.2	346
		8000	376	603.83	55.2/55.2	0.52	115.0	3.6	
		8500	400	633.42	55.5/55.5	0.57	121.0	3.9	
		9000	424	661.89	55.9/55.9	0.63	126.0	4.2	
		9500	447	690.70	56.3/56.3	0.68	132.0	4.6	
		10,000	471	718.87	56.7/56.7	0.74	137.0	5.0	
		10,500	494	745.65	56.7/56.7	0.80	142.0	5.3	
51 x 80		11,000	388	844.01	54.8/54.8	0.55	160.0	6.2	449
		11,500	406	875.80	55.2/55.1	0.59	167.0	6.8	
		12,000	424	906.79	55.2/55.2	0.63	173.0	7.2	
		12,500	441	935.43	55.5/55.5	0.67	178.0	7.6	
		13,000	459	964.88	55.7/55.7	0.71	184.0	8.1	
		13,500	477	994.10	55.9/55.9	0.76	189.0	8.6	
		14,000	494	1023.05	56.3/56.2	0.81	195.0	9.1	
	14,500	512	1052.00	56.6/56.6	0.86	200.0	9.6		

1. Nominal cooling capacity based on a 6 row/ 8 FPI chilled water coil with 45°F EWT, 55°F LWT and 95°/ 77° entering air temperature.
2. Ask your local representative for a computer print out showing coil performance for conditions different than those shown above.
3. Coil weight is for 6 Row/ 8 FPI dry coil. This weight must be added to coil section weight shown on page 25.

Coil Performance Data

8 Row CW									
Model	Coil Face Area FH x FL	CFM	Face Velocity (FPM)	8 Row CW					
				Total MBH ⁽¹⁾	LAT	Air P.D.	GPM	FPD (ft)	WEIGHT (LBS)
20	24 x 36	1500	250	134.32	50.4/50.4	0.38	26.8	1.3	150
		2000	333	169.43	51.6/51.6	0.58	32.3	2.3	
		2500	417	204.97	52.8/52.8	0.81	39.0	3.3	
		3000	500	238.10	53.6/53.6	1.09	45.4	4.4	
	24 x 63	3500	333	313.83	49.7/49.7	0.58	59.5	8.3	246
		4000	381	352.46	50.5/50.5	0.71	67.0	10.2	
		4500	429	389.48	50.9/50.9	0.86	74.0	12.3	
		5000	476	425.95	51.6/51.6	1.02	81.0	13.7	
40	30 x 44	3000	327	260.67	50.9/50.9	0.56	49.7	4.3	216
		3500	382	297.99	51.6/51.6	0.71	57.0	4.4	
		4000	436	333.78	52.0/52.0	0.88	63.6	5.4	
		4500	491	368.18	52.8/52.8	1.06	70.2	6.5	
	36 x 56	5000	357	441.03	50.3/50.3	0.65	84.0	7.0	313
		5500	393	476.97	50.9/50.9	0.75	91.0	8.1	
		6000	429	514.34	51.3/51.3	0.86	98.0	9.2	
		6500	464	550.78	51.6/51.6	0.97	105.0	10.5	
		7000	500	585.19	52.0/52.0	1.10	111.0	11.6	
		7500	424	650.47	50.9/50.9	0.84	124.0	12.6	
	40.5 x 63	8000	452	687.59	51.3/51.3	0.93	131.0	13.9	386
		8500	480	722.66	51.6/51.6	1.03	137.0	15.1	
		9000	508	759.05	51.6/51.6	1.13	144.0	16.6	
		9500	537	795.34	52.0/52.0	1.23	152.0	18.3	
60	42 x 48	4500	321	395.23	50.5/50.5	0.55	75.0	4.8	313
		5000	357	432.89	50.9/50.9	0.64	82.0	4.8	
		5500	393	470.70	51.3/51.3	0.75	90.0	5.7	
		6000	429	507.15	51.6/51.6	0.86	97.0	6.5	
		6500	464	541.75	52.0/52.0	0.97	103.0	7.3	
		7000	500	576.29	52.4/52.4	1.10	110.0	8.2	
	45 x 68	7500	353	625.87	52.0/52.0	0.63	119.0	2.9	454
		8000	376	660.47	52.4/52.4	0.69	126.0	3.2	
		8500	400	696.45	52.8/52.8	0.76	133.0	3.6	
		9000	424	729.64	53.2/53.2	0.84	139.0	3.9	
		9500	447	762.57	53.2/53.2	0.91	145.0	4.2	
		10,000	471	795.60	53.6/53.6	0.99	151.0	4.6	
		10,500	494	827.81	54.0/54.0	1.07	157.0	4.9	
	51 x 80	11,000	388	924.30	52.0/52.0	0.73	176.0	5.9	590
		11,500	406	959.96	52.0/52.0	0.78	183.0	6.3	
		12,000	424	994.24	52.4/52.4	0.84	190.0	6.8	
		12,500	441	1027.82	52.4/52.4	0.89	196.0	7.2	
		13,000	459	1063.37	52.8/52.8	0.95	202.0	7.6	
		13,500	477	1095.36	53.0/53.0	1.01	208.0	8.1	
		14,000	494	1129.25	53.2/53.2	1.07	215.0	8.6	

1. Nominal cooling capacity based on a 8 row/ 8 FPI chilled water coil with 45°F EWT, 55°F LWT and 95°/ 77° entering air temperature.
2. Ask your local representative for a computer print out showing coil performance for conditions different than those shown above.
3. Coil weight is for 8 Row/ 8 FPI dry coil. This weight must be added to coil section weight shown on page 25.

Air Delivery Table

Model IFL-20												
CFM		Total Static Pressure (Inches Water Column)										
		1.00	1.50	2.00	2.50	3.00	3.50	4.00	4.50	5.00	5.50	6.00
1500	RPM	2099	2287	2464	2629	2783	2925	3063	3202	–	–	–
	BHP/MHP	0.45/1	0.62/1	0.81/1	1.01/1.5	1.21/1.5	1.40/2	1.60/2	1.80/2	–	–	–
	Wheel Size	122	122	122	122	122	122	122	122	–	–	–
2000	RPM	1906	2068	2221	2364	2500	2624	2742	2859	3636	3747	3854
	BHP/MHP	0.61/1	0.84/1	1.09/1.5	1.35/2	1.62/2	1.87/3	2.13/3	2.39/3	2.69/3	2.95/5	3.20/5
	Wheel Size	150	150	150	150	150	150	150	150	122-II	122-II	122-II
2500	RPM	1681	1826	1962	2091	2212	2323	2428	2534	3188	3286	3381
	BHP/MHP	0.76/1	1.05/1.5	1.35/2	1.69/2	2.02/3	2.34/3	2.66/3	3.00/5	3.36/5	3.68/5	4.00/5
	Wheel Size	165	165	165	165	165	165	165	165	150-II	150-II	150-II
3000	RPM	1899	2032	2154	2270	2381	2488	2591	2688	2780	2868	2956
	BHP/MHP	1.03/1.5	1.35/2	1.70/2	2.05/3	2.44/3	2.83/5	3.23/5	3.63/5	4.01/5	4.39/5	4.78/7.5
	Wheel Size	165	165	165	165	165	165	165-II	165-II	165-II	165-II	165-II
3500	RPM	1303	1431	1551	1668	1783	1896	2005	2112	2945	3032	3116
	BHP/MHP	0.92/1.5	1.28/1.5	1.65/2	2.05/3	2.46/3	2.90/5	3.36/5	3.85/5	4.72/7.5	5.19/7.5	5.65/7.5
	Wheel Size	182	182	182	182	182	182	182	182	165-II	165-II	165-II
4000	RPM	1416	1534	1644	1749	1852	1954	2054	2153	2249	2343	2436
	BHP/MHP	1.14/1.5	1.53/2	1.94/3	2.36/3	2.81/5	3.28/5	3.76/5	4.26/5	4.78/7.5	5.32/7.5	5.88/7.5
	Wheel Size	182	182	182	182	182	182	182	182	182-II	182-II	182-II
4500	RPM	1528	1644	1745	1843	1938	2029	2120	2221	2300	2388	2474
	BHP/MHP	1.38/2	1.82/3	2.27/3	2.73/3	3.21/5	3.70/5	4.21/5	4.74/7.5	5.28/7.5	5.84/7.5	6.41/7.5
	Wheel Size	182	182	182	182	182	182	182	182-II	182-II	182-II	182-II
5000	RPM	1643	1757	1854	1945	2033	2119	2202	2284	2366	2447	2528
	BHP/MHP	1.66/2	2.16/3	2.64/3	3.14/5	3.65/5	4.19/5	4.72/7.5	5.28/7.5	5.85/7.5	6.44/7.5	7.04/7.5
	Wheel Size	182	182	182	182	182	182	182	182-II	182-II	182-II	182-II

BHP Numbers DO NOT Include Drive Loss

- Notes: 1) Selections in shaded area indicate Class II wheels.
 2) Motor HP (MHP) selections include drive loss.

Air Delivery Table

Model IFL-40												
CFM		Total Static Pressure (Inches Water Column)										
		1.00	1.50	2.00	2.50	3.00	3.50	4.00	4.50	5.00	5.50	6.00
3000	RPM	1899	2032	2154	2270	2381	2488	2591	2688	2780	2868	2956
	BHP / HP	1.03/1.5	1.35/2	1.70/2	2.05/3	2.44/3	2.83/5	3.23/5	3.63/5	4.01/5	4.39/5	4.78/7.5
	WHEEL SIZE	165	165	165	165	165	165	165-II	165-II	165-II	165-II	165-II
3500	RPM	1303	1431	1551	1668	1783	1896	2005	2112	2245	3032	3116
	BHP / HP	0.92/1.5	1.28/1.5	1.65/2	2.05/3	2.46/3	2.90/5	3.36/5	3.85/5	4.72/7.5	5.19/7.5	5.65/7.5
	WHEEL SIZE	182	182	182	182	182	182	182	182	165-II	165-II	165-II
4000	RPM	1416	1534	1644	1749	1852	1954	2054	2153	2249	2343	2436
	BHP / HP	1.14/1.5	1.53/2	1.94/3	2.36/3	2.81/5	3.28/5	3.76/5	4.26/5	4.78/7.5	5.32/7.5	5.88/7.5
	WHEEL SIZE	182	182	182	182	182	182	182	182	182-II	182-II	182-II
4500	RPM	1528	1644	1745	1843	1938	2029	2120	2221	2300	2388	2474
	BHP / HP	1.38/2	1.82/3	2.27/3	2.73/3	3.21/5	3.70/5	4.21/5	4.74/7.5	5.28/7.5	5.84/7.5	6.41/7.5
	WHEEL SIZE	182	182	182	182	182	182	182	182-II	182-II	182-II	182-II
5000	RPM	1643	1757	1854	1945	2033	2119	2202	2284	2366	2447	2528
	BHP / HP	1.66/2	2.16/3	2.64/3	3.14/5	3.65/5	4.19/5	4.72/7.5	5.28/7.5	5.85/7.5	6.44/7.5	7.04/7.5
	WHEEL SIZE	182	182	182	182	182	182	182	182-II	182-II	182-II	182-II
5500	RPM	1411	1516	1608	1696	1781	1864	1964	2027	2107	2521	2595
	BHP / HP	1.71/2	2.25/3	2.79/5	3.35/5	3.93/5	4.53/5	5.16/7.5	5.79/7.5	6.45/7.5	7.10/10	7.72/10
	WHEEL SIZE	200	200	200	200	200	200	200	200-II	200-II	182-II	182-II
6000	RPM	1493	1602	1691	1774	1855	1933	2009	2084	2158	2233	2306
	BHP / HP	1.99/3	2.59/3	3.17/5	3.77/5	4.39/5	5.02/7.5	5.67/7.5	6.34/7.5	7.02/7.5	7.73/10	8.44/10
	WHEEL SIZE	200	200	200	200	200	200	200-II	200-II	200-II	200-II	200-II
6500	RPM	1587	1688	1776	1856	1932	2006	2078	2149	2218	2287	2356
	BHP / HP	2.31/3	2.96/5	3.59/5	4.23/5	4.88/7.5	5.54/7.5	6.22/7.5	6.93/7.5	7.64/10	8.37/10	9.12/10
	WHEEL SIZE	200	200	200	200	200	200-II	200-II	200-II	200-II	200-II	200-II
7000	RPM	1679	1774	1862	1940	2013	2083	2152	2220	2286	2351	2415
	BHP / HP	2.67/3	3.36/5	4.05/5	4.73/7.5	5.42/7.5	6.12/7.5	6.84/7.5	7.57/10	8.32/10	9.09/10	10.20/15
	WHEEL SIZE	200	200	200	200	200-II	200-II	200-II	200-II	200-II	200-II	200-II
7500	RPM	1773	1861	1948	2026	2097	2164	2229	2294	2358	2420	2481
	BHP / HP	3.07/5	3.79/5	4.55/5	5.28/7.5	6.02/7.5	6.75/7.5	7.49/10	8.27/10	9.06/10	9.85/15	10.66/15
	WHEEL SIZE	200	200	200	200-II	200-II	200-II	200-II	200-II	200-II	200-II	200-II
8000	RPM	1383	1467	1544	1617	1688	1757	1825	1891	1955	2017	2078
	BHP / HP	2.64/3	3.38/5	4.13/5	4.90/7.5	5.70/7.5	6.51/7.5	7.34/10	8.20/10	9.06/10	9.93/15	10.83/15
	WHEEL SIZE	222	222	222	222	222	222	222-II	222-II	222-II	222-II	222-II
8500	RPM	1448	1529	1604	1674	1742	1809	1874	1937	1999	2060	2119
	BHP / HP	2.97/5	3.75/5	4.54/5	5.35/7.5	6.18/7.5	7.04/7.5	7.90/10	8.78/10	9.68/15	10.60/15	11.52/15
	WHEEL SIZE	222	222	222	222	222	222-II	222-II	222-II	222-II	222-II	222-II
9000	RPM	1514	1592	1665	1733	1798	1862	1924	1986	2046	2104	2162
	BHP / HP	3.33/5	4.15/5	4.98/7.5	5.83/7.5	6.69/7.5	7.58/10	8.48/10	9.41/10	10.34/15	11.28/15	12.25/15
	WHEEL SIZE	222	222	222	222	222-II	222-II	222-II	222-II	222-II	222-II	222-II
9500	RPM	1580	1656	1726	1793	1856	1917	1977	2036	2094	2151	2207
	BHP / HP	3.72/5	4.58/5	5.45/7.5	6.34/7.5	7.24/10	8.16/10	9.10/10	10.06/15	11.03/15	12.01/15	13.01/15
	WHEEL SIZE	222	222	222	222-II	222-II	222-II	222-II	222-II	222-II	222-II	222-II

BHP Numbers DO NOT Include Drive Loss

- Notes: 1) Selections in shaded area indicate Class II wheels.
 2) Motor HP (MHP) selections include drive loss.

Air Delivery Table

Model IFL-60												
CFM		Total Static Pressure (Inches Water Column)										
		1.00	1.50	2.00	2.50	3.00	3.50	4.00	4.50	5.00	5.50	6.00
4500	RPM	1528	1644	1745	1843	1938	2029	2120	2221	2300	2388	2474
	BHP /MHP	1.38/2	1.82/3	2.27/3	2.73/3	3.21/5	3.70/5	4.21/5	4.74/7.5	5.28/7.5	5.84/7.5	6.41/7.5
	WHEEL SIZE	182	182	182	182	182	182	182	182-II	182-II	182-II	182-II
5000	RPM	1643	1757	1854	1945	2033	2119	2202	2284	2366	2447	2528
	BHP /MHP	1.66/2	2.16/3	2.64/3	3.14/5	3.65/5	4.19/5	4.72/7.5	5.28/7.5	5.85/7.5	6.44/7.5	7.04/7.5
	WHEEL SIZE	182	182	182	182	182	182	182	182-II	182-II	182-II	182-II
5500	RPM	1411	1516	1608	1696	1781	1864	1964	2027	2107	2521	2595
	BHP /MHP	1.71/2	2.25/3	2.79/5	3.35/5	3.93/5	4.53/5	5.16/7.5	5.79/7.5	6.45/7.5	7.10/10	7.72/10
	WHEEL SIZE	200	200	200	200	200	200	200	200-II	200-II	182-II	182-II
6000	RPM	1493	1602	1691	1774	1855	1933	2009	2084	2158	2233	2306
	BHP /MHP	1.99/3	2.59/3	3.17/5	3.77/5	4.39/5	5.02/7.5	5.67/7.5	6.34/7.5	7.02/7.5	7.73/10	8.44/10
	WHEEL SIZE	200	200	200	200	200	200	200	200-II	200-II	200-II	200-II
6500	RPM	1587	1688	1776	1856	1932	2006	2078	2149	2218	2287	2356
	BHP /MHP	2.31/3	2.96/5	3.59/5	4.23/5	4.88/7.5	5.54/7.5	6.22/7.5	6.93/7.5	7.64/10	8.37/10	9.12/10
	WHEEL SIZE	200	200	200	200	200	200-II	200-II	200-II	200-II	200-II	200-II
7000	RPM	1679	1774	1862	1940	2013	2083	2152	2220	2286	2351	2415
	BHP /MHP	2.67/3	3.36/5	4.05/5	4.73/7.5	5.42/7.5	6.12/7.5	6.84/7.5	7.57/10	8.32/10	9.09/10	10.20/15
	WHEEL SIZE	200	200	200	200	200-II	200-II	200-II	200-II	200-II	200-II	200-II
7500	RPM	1773	1861	1948	2026	2097	2164	2229	2294	2358	2420	2481
	BHP /MHP	3.07/5	3.79/5	4.55/5	5.28/7.5	6.02/7.5	6.75/7.5	7.49/10	8.27/10	9.06/10	9.85/15	10.66/15
	WHEEL SIZE	200	200	200	200-II	200-II	200-II	200-II	200-II	200-II	200-II	200-II
8000	RPM	1383	1467	1544	1617	1688	1757	1825	1891	1955	2017	2078
	BHP / HP	2.64/3	3.38/5	4.13/5	4.90/7.5	5.70/7.5	6.51/7.5	7.34/10	8.20/10	9.06/10	9.93/15	10.83/15
	WHEEL SIZE	222	222	222	222	222	222	222-II	222-II	222-II	222-II	222-II
8500	RPM	1448	1529	1604	1674	1742	1809	1874	1937	1999	2060	2119
	BHP /MHP	2.97/5	3.75/5	4.54/5	5.35/7.5	6.18/7.5	7.04/7.5	7.90/10	8.78/10	9.68/15	10.60/15	11.52/15
	WHEEL SIZE	222	222	222	222	222	222-II	222-II	222-II	222-II	222-II	222-II
9000	RPM	1514	1592	1665	1733	1798	1862	1924	1986	2046	2104	2162
	BHP /MHP	3.72/5	4.58/5	5.45/7.5	6.34/7.5	7.24/10	8.16/10	9.10/10	10.06/15	11.03/15	12.01/15	13.01/15
	WHEEL SIZE	222	222	222	222	222-II	222-II	222-II	222-II	222-II	222-II	222-II
9500	RPM	1580	1656	1726	1793	1856	1917	1977	2036	2094	2151	2207
	BHP /MHP	3.72/5	4.58/5	5.45/7.5	6.34/7.5	7.24/10	8.16/10	9.10/10	10.06/15	11.03/15	12.01/15	13.01/15
	WHEEL SIZE	222	222	222	222-II	222-II	222-II	222-II	222-II	222-II	222-II	222-II
10,000	RPM	1647	1720	1788	1854	1915	1974	2032	2089	2145	2200	2254
	BHP /MHP	4.14/5	5.04/7.5	5.95/7.5	6.89/7.5	7.83/10	8.78/10	9.76/15	10.76/15	11.76/15	12.78/15	13.81/15
	WHEEL SIZE	222	222	222-II	222-II	222-II	222-II	222-II	222-II	222-II	222-II	222-II
10,500	RPM	1359	1431	1500	1564	1624	1682	1739	1793	1846	1898	1949
	BHP /MHP	3.85/5	4.83/7.5	5.83/7.5	6.82/7.5	7.79/10	8.79/10	9.82/15	10.87/15	11.95/15	13.05/15	14.16/15
	WHEEL SIZE	245	245	245	245	245-II	245-II	245-II	245-II	245-II	245-II	245-II
11,000	RPM	1409	1480	1546	1609	1668	1725	1780	1833	1885	1935	1985
	BHP /MHP	4.22/5	5.25/7.5	6.30/7.5	7.34/10	8.36/10	9.40/10	10.50/15	11.53/15	12.64/15	13.76/15	14.93/20
	WHEEL SIZE	245	245	245	245	245-II	245-II	245-II	245-II	245-II	245-II	245-II
11,500	RPM	1461	1529	1593	1655	1713	1768	1822	1874	1925	1974	2022
	BHP /MHP	4.64/5	5.70/7.5	6.78/7.5	7.89/10	8.96/10	10.03/15	11.12/15	12.23/15	13.37/15	14.53/20	15.70/20
	WHEEL SIZE	245	245	245	245-II	245-II	245-II	245-II	245-II	245-II	245-II	245-II
12,000	RPM	1512	1578	1641	1701	1758	1812	1864	1915	1965	2014	2061
	BHP /MHP	5.08/7.5	6.17/7.5	7.31/10	8.45/10	9.58/15	10.69/15	11.81/15	12.95/15	14.12/15	15.32/20	16.53/20
	WHEEL SIZE	245	245	245-II	245-II	245-II	245-II	245-II	245-II	245-II	245-II	245-II
12,500	RPM	1565	1628	1689	1748	1804	1857	1908	1958	2006	2054	2102
	BHP /MHP	5.56/7.5	6.68/7.5	7.85/10	9.05/10	10.24/15	11.40/15	12.56/15	13.73/15	14.91/20	16.14/20	16.92/20
	WHEEL SIZE	245	245-II	245-II	245-II	245-II	245-II	245-II	245-II	245-II	245-II	245-II
13,000	RPM	1264	1327	1385	1440	1492	1543	1594	1644	1693	1742	1790
	BHP /MHP	4.89/7.5	6.04/7.5	7.21/10	8.42/10	9.62/15	10.92/15	12.33/15	13.54/15	14.88/20	16.26/20	17.66/20
	WHEEL SIZE	270	270	270	270	270-II	270-II	270-II	270-II	270-II	270-II	270-II
13,500	RPM	1303	1364	1421	1475	1526	1576	1624	1673	1721	1768	1815
	BHP /MHP	5.29/7.5	6.48/7.5	7.69/10	8.94/10	10.21/15	11.52/15	12.63/15	14.19/15	15.57/20	16.96/20	18.40/20
	WHEEL SIZE	270	270	270	270-II	270-II	270-II	270-II	270-II	270-II	270-II	270-II
14,000	RPM	1341	1402	1457	1511	1561	1609	1656	1703	1750	1796	1842
	BHP /MHP	5.70/7.5	6.95/7.5	8.19/10	9.49/10	10.79/15	12.12/15	13.47/15	14.88/20	16.29/20	17.72/20	19.19/25
	WHEEL SIZE	270	270	270-II	270-II	270-II	270-II	270-II	270-II	270-II	270-II	270-II

BHP Numbers DO NOT Include Drive Loss

- 1) Selections in shaded area indicate Class II wheels.
- 2) Motor HP (MHP) selections include drive loss.

Dimensional Data

C00636A

UNIT COMPONENTS

- | | | | |
|--------------------------------|------------------------------|------------------------------|-----------------------------|
| 1. Plenum Supply Fan | 6. Burner Access Door | 11. Coil 2" Flat Filter Rack | 16. Access Door |
| 2. Fan Motor | 7. Lift Off Access Door | 12. Cooling Coil | 17. Heat Exchanger Stack |
| 3. Heat Exchanger | 8. Coil / Filter Access Door | 13. Flat Filter Access Door | 18. Field Power Entry Point |
| 4. Control Cabinet | 9. Condensate Drain | 14. Lifting Lug (Typical) | 19. Side Discharge |
| 5. Control Cabinet Access Door | 10. Coil Cleanout Access | 15. Hood Filters (Optional) | 20. Down Discharge |

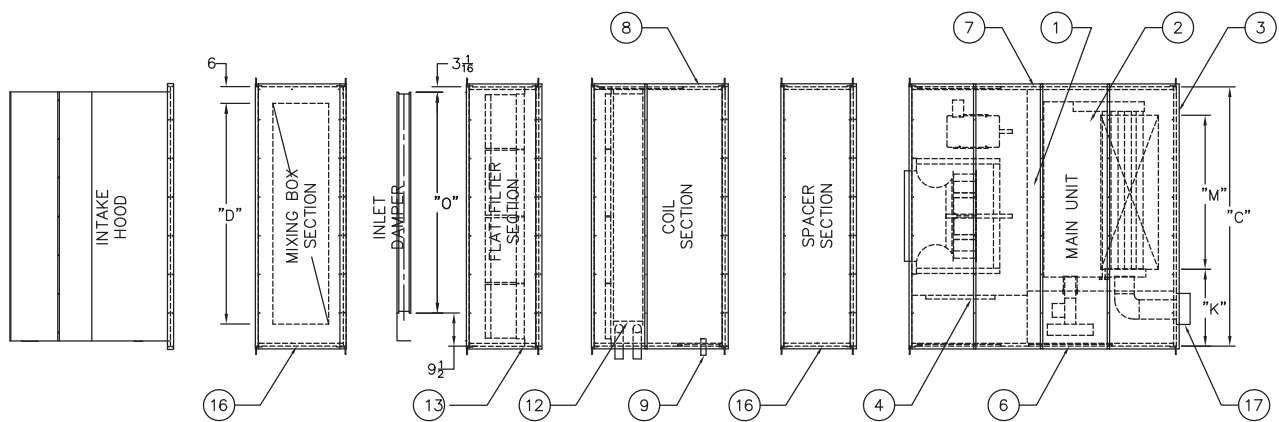

PLAN VIEW

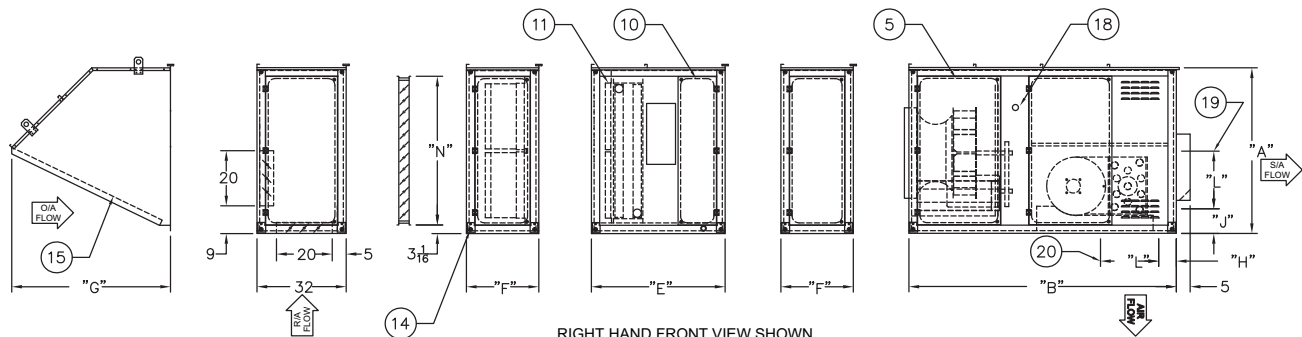

RIGHT HAND FRONT VIEW SHOWN
LEFT HAND IS OPPOSITE

Model	Dimensions													
	A	B	C*	D	E	F	G	H	J	K	L	M	N	O
20	36	72	76	64	48	26	23 5/16	3 1/16	6 3/8	28 11/16	14 1/2	40	29 7/8	63 7/16
40	50	82	80	68	48	26	38 5/8	3 1/16	6 3/4	25 11/16	20 3/4	46	43 7/8	67 7/16
60	60	96	94	82	48	26	57 3/4	6 3/8	8 15/16	27 13/16	20 7/8	56	53 7/8	81 7/16

* Allow 3' Of Clearance On Both Sides For Access.

Roof Curb and Gas Piping Layout

IFL Roof Curb

C000688

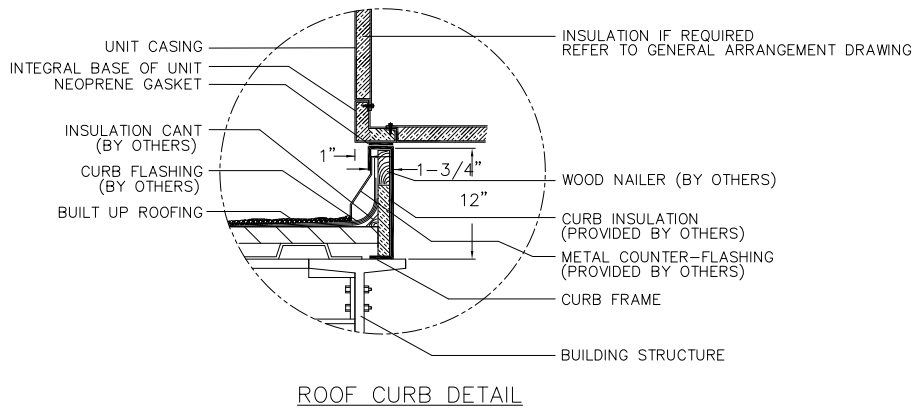
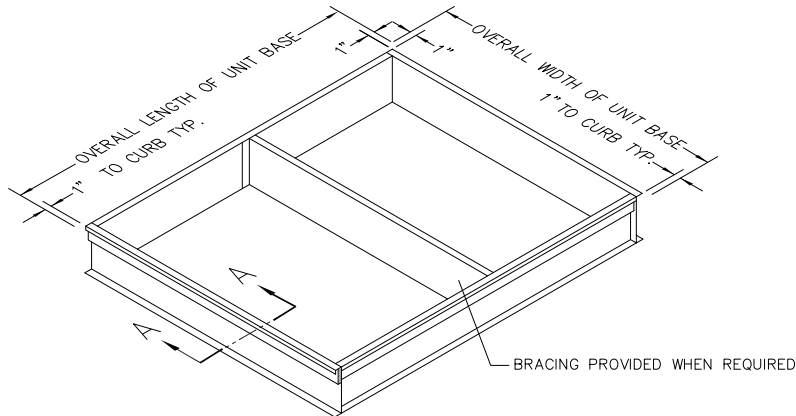

Schematic Component Diagrams

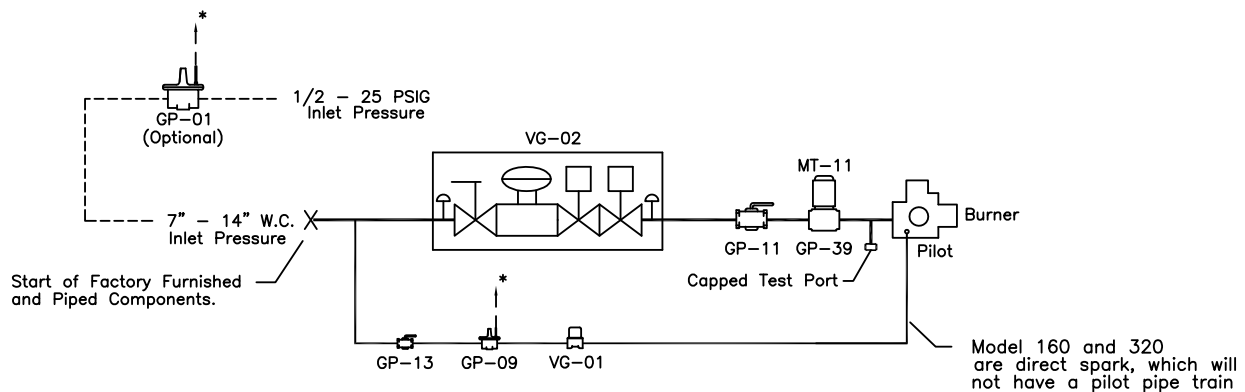

STANDARD & FM & IRI SIZES 160 UP TO 480

COMPONENT IDENTIFICATION

GP-01 HIGH GAS PRESSURE REGULATOR (OPTIONAL)
 GP-09 PILOT GAS PRESSURE REGULATOR
 GP-11 FIRING VALVE (3)
 GP-13 PILOT FIRING VALVE
 GP-39 MODULATING VALVE
 MT-11 MODULATING VALVE MOTOR

VG-01 PILOT GAS VALVE
 VG-02 MAIN GAS VALVE

NOTES:

- * 1. Vent limiting devices provided wherever possible, when venting is required the venting to outside is by others on indoor units and furnished by factory on outdoor units.
2. For inlet pressures under 7" W.C. please consult factory.
3. Firing valve not included on sizes 160 and 320 burners.

MDT Control System

C000673

Application:	Includes:
Modulating Discharge Temperature Control	Discharge air sensor (5) mounted in unit discharge with remote mounted 3 gang box cover (6) including manual potentiometer to enable unit and adjust temperature setpoint, Fan On Light, Burner On Light, and Cool On Light. Additional potentiometer is provided if optional return damper section for manual or mixed air control is ordered.

COMPONENT I.D.

- | | | |
|-------------------------|-------------------------|---------------------------|
| 1. Unit DDC Controller | 3. Inlet Air Sensor | 5. Remote Control Station |
| 2. Modulating Gas Valve | 4. Discharge Air Sensor | |

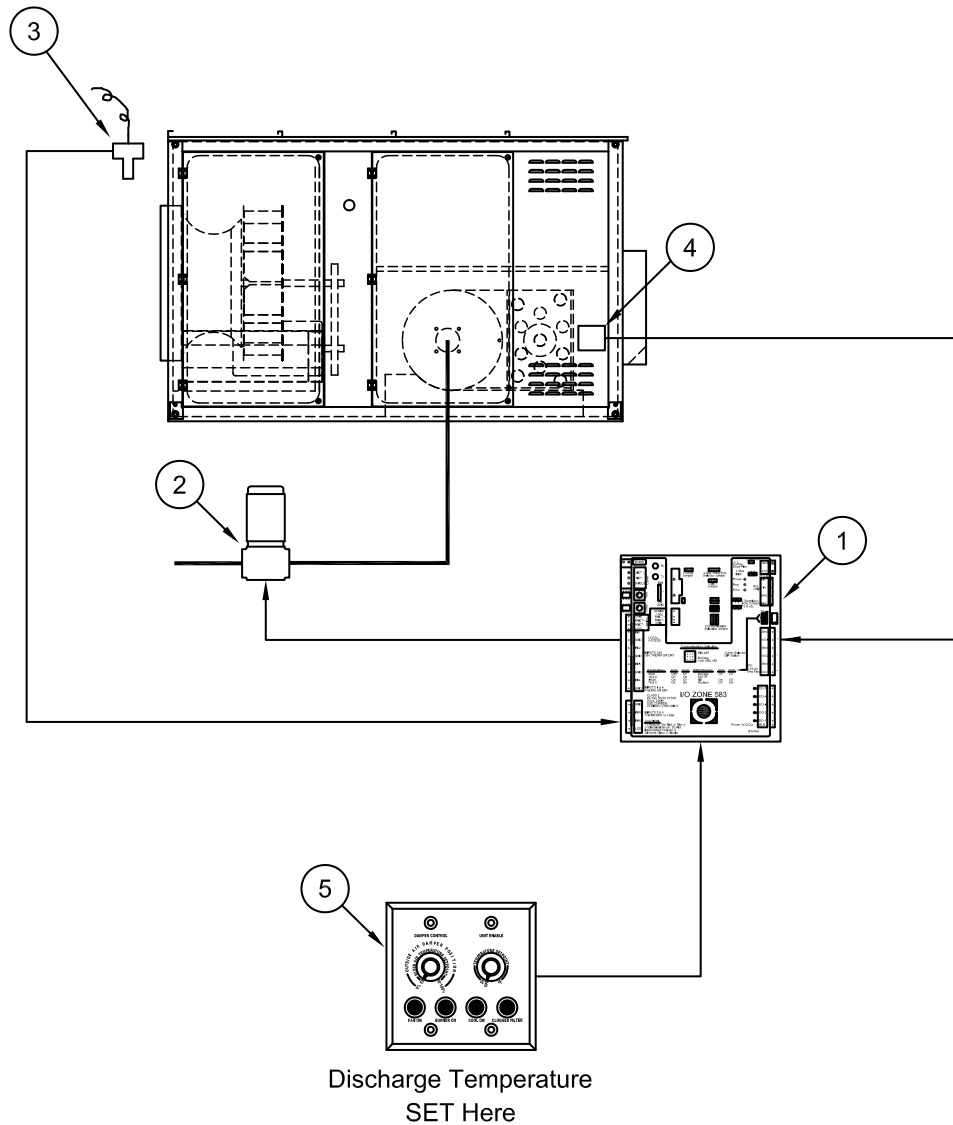

MRT Control System

C000674

Application:

Modulating Room
Temperature Control

Includes:

Discharge air sensor (5) mounted in unit discharge with remote mounted 3 gang box cover (7) including manual potentiometer to enable unit and adjust temperature setpoint, Fan On Light, Burner On Light, and Cool On Light. Also includes RS-std room sensor (6) (does not allow remote room setpoint adjustment). Additional potentiometer is provided if optional return damper section for manual or mixed air control is ordered.

COMPONENT I.D.

- 1. Unit DDC Controller
- 2. Modulating Gas Valve

- 3. Inlet Air Sensor
- 4. Discharge Air Sensor

- 5. Remote Control Station
- 6. Room Thermostat

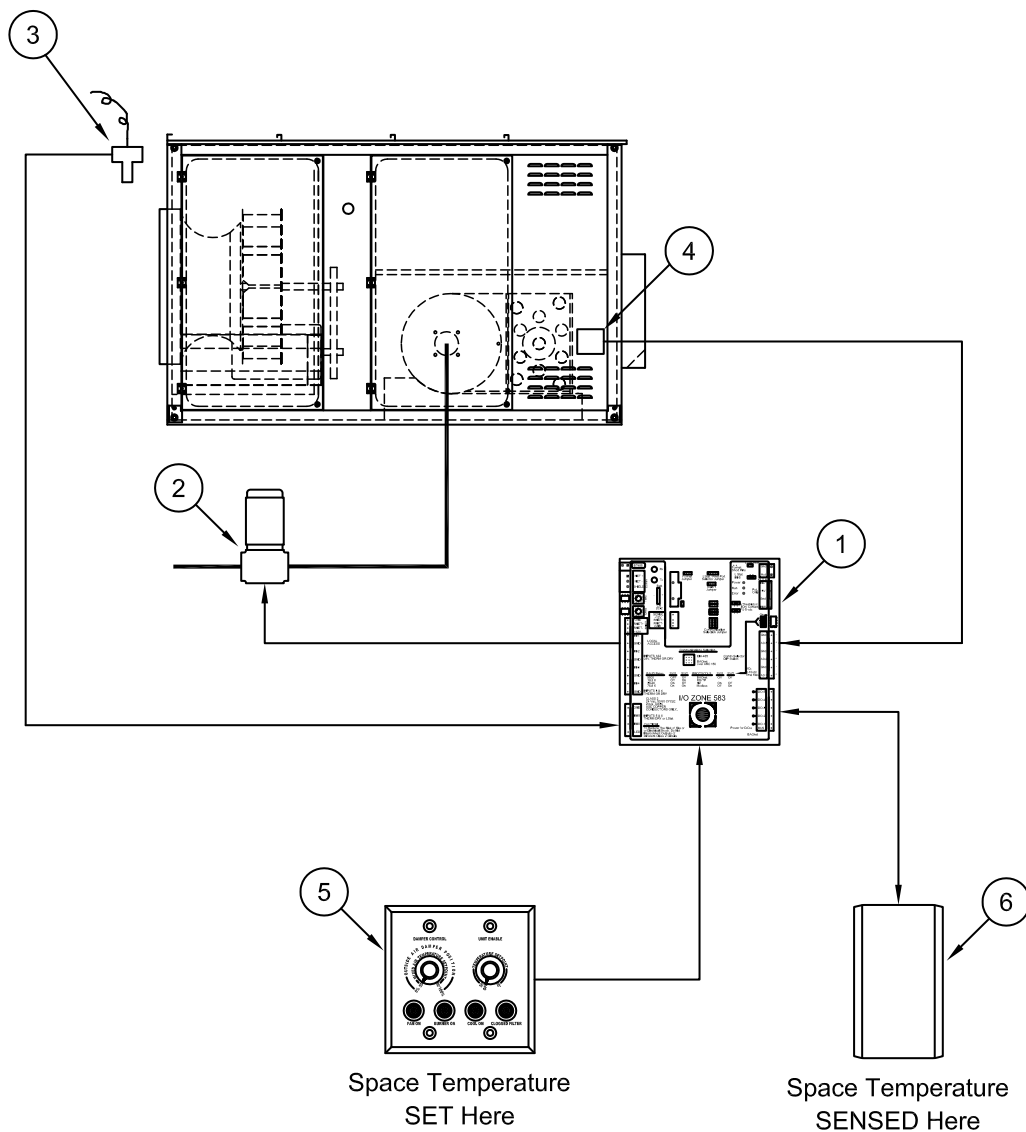

Application:

Modulating Room Temperature Control with BACView controller allowing after hours unit enable, room setpoint adjustment, operating feedback, monitoring of alarm status and digital temperature readout with RS-std room sensor.

Includes:

Discharge air sensor (5) mounted in unit discharge with remote mounted BACView controller (7) to set space temp, operating schedules, and optional damper control setpoints. Service information, operating feedback and alarm status can also be monitored. Also includes a RS-std room sensor (6).

COMPONENT I.D.

- | | | |
|-------------------------|-------------------------|----------------------|
| 1. Unit DDC Controller | 3. Inlet Air Sensor | 5. Room Thermostat |
| 2. Modulating Gas Valve | 4. Discharge Air Sensor | 6. BACView Interface |

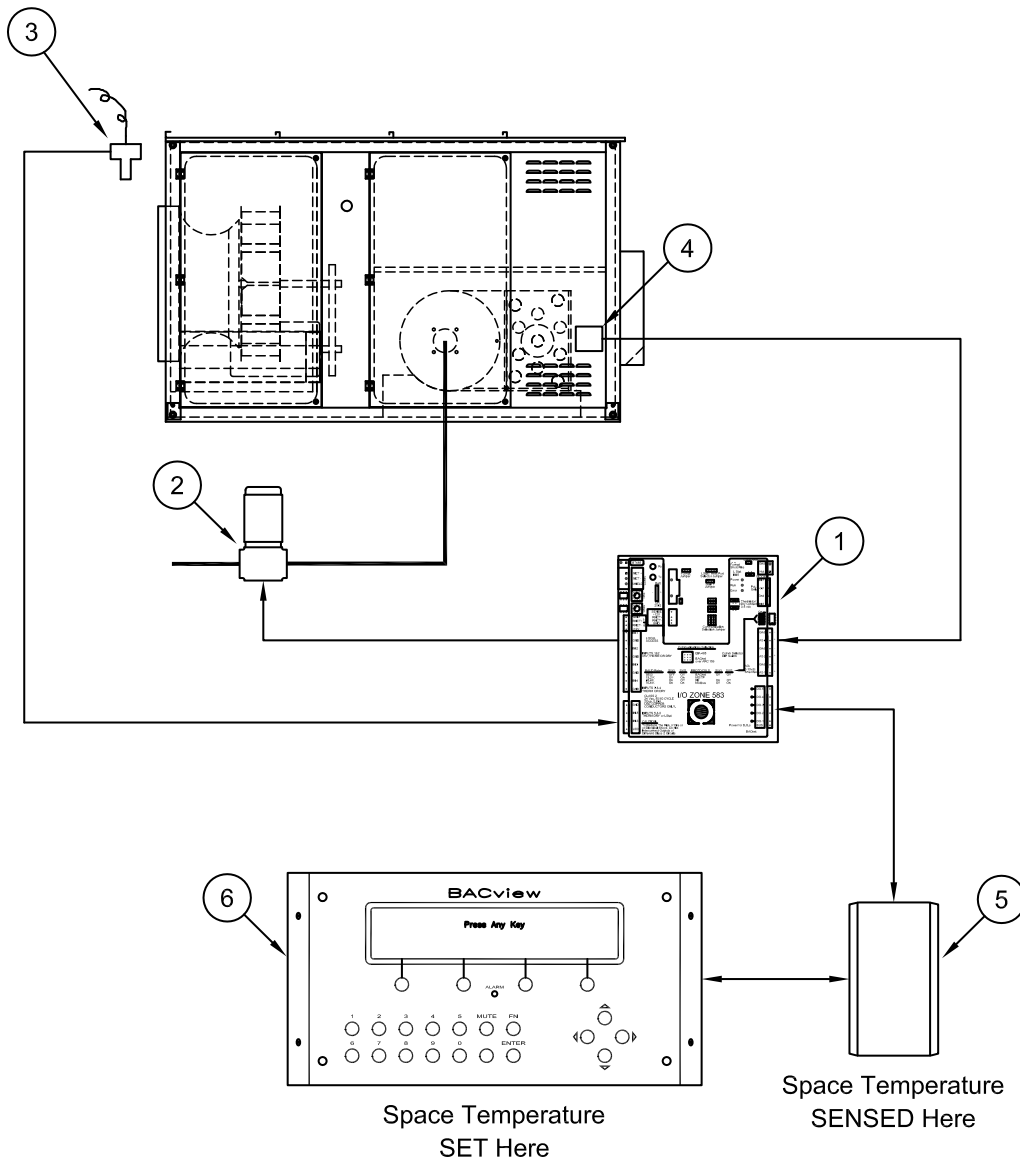

Application:	Includes:
Modulating Discharge Temperature Control with BACView controller allowing after hours unit enable, operating feedback, and monitoring of alarm status.	Discharge air sensor (4) mounted in unit discharge with remote mounted BACView controller (5) to set discharge temperature setpoint and operating schedules. Service information, operating feedback, and alarm status can also be monitored.

COMPONENT I.D.

- | | | |
|-------------------------|-------------------------|----------------------|
| 1. Unit DDC Controller | 3. Inlet Air Sensor | 5. BACView Interface |
| 2. Modulating Gas Valve | 4. Discharge Air Sensor | |

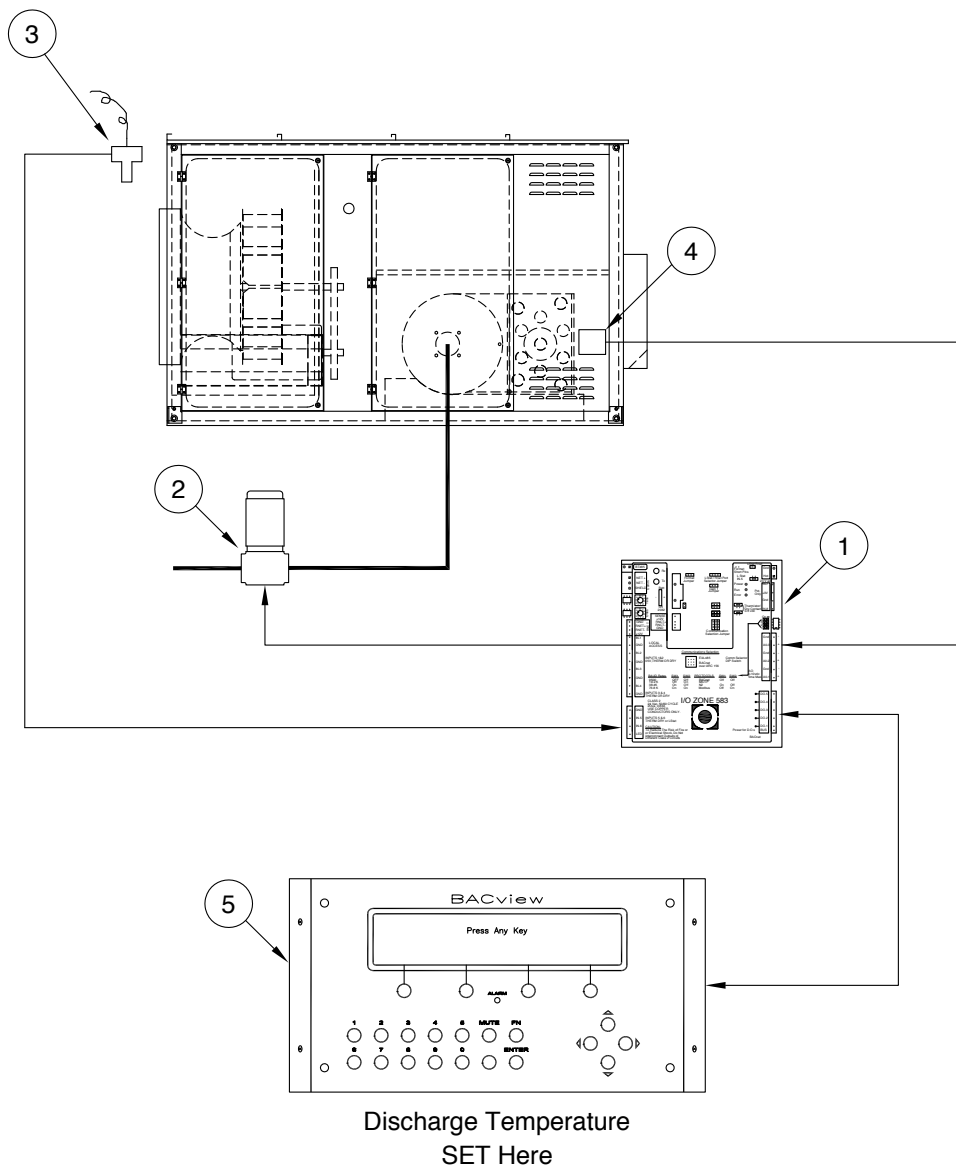

Typical Wiring

C000641C

COMPONENT IDENTIFICATION

- BC-01 BURNER BLOWER MOTOR CONTROL
- CB-09 CONTROL CIRCUIT TRANSFORMER BREAKER
- FL-02 HIGH TEMPERATURE LIMIT SWITCH
- FL-04 MANUAL RESET HIGH LIMIT SWITCH (OPTIONAL)
- FL-05 SUPPLY AIR FIRESTAT (OPTIONAL)
- FL-06 RETURN AIR FIRESTAT (OPTIONAL)
- FU-10 CONTROL TRANSFORMER FUSE
- GA-03 COMBINATION CO & NO2 DETECTOR (OPTIONAL)
- GA-04 CARBON DIOXIDE DETECTOR (OPTIONAL)
- KP-01 KEYPAD /DISPLAY MODULE (OPTIONAL)
- LT-05 BURNER ON LIGHT (OPTIONAL)
- LT-15 FAN ON LIGHT (OPTIONAL)
- LT-31 COOLING ON LIGHT (OPTIONAL)
- LT-59 CLOGGED FILTER LIGHT (OPTIONAL)
- MP-05 DAMPER CONTROL POTENTIOMETER (OPTIONAL)
- MP-15 UNIT ENABLE POTENTIOMETER (OPTIONAL)
- MT-01 MAIN SUPPLY FAN MOTOR
- MT-08 BURNER MOTOR
- MT-11 MODULATING GAS VALVE MOTOR
- MT-13 DAMPER MOTOR (OPTIONAL)
- OL-01 MAIN FAN MOTOR OVERLOAD
- PS-02 BURNER AIRFLOW PROVING SWITCH
- PS-04 LOW GAS PRESSURE SWITCH (OPTIONAL)
- PS-07 HIGH GAS PRESSURE SWITCH (OPTIONAL)
- PS-12 CLOGGED FILTER SWITCH (OPTIONAL)
- PT-13 BUILDING PRESSURE TRANSDUCER (OPTIONAL)
- RE-02 FLAME SAFEGUARD RELAY
- RE-06 BURNER STATUS RELAY
- RE-12 CLOGGED FILTER RELAY (OPTIONAL)
- RE-21 7-DAY TIME CLOCK (OPTIONAL)
- RE-28 BURNER ENABLE RELAY
- RE-34 COOLING ENABLE RELAY
- RE-35 COOLING INTERLOCK RELAY
- RE-56 SAFTEY CIRCUIT STATUS RELAY
- RE-57 UNIT ENABLE RELAY
- RE-65 FAN STATUS RELAY
- RE-78 INTERLOCKING RELAY (OPTIONAL)
- RE-80 LOW ALERT RELAY (OPTIONAL)
- RE-81 HIGH ALERT RELAY (OPTIONAL)
- RE-82 CO2 ALARM RELAY (OPTIONAL)
- RS-01 RESISTOR 1K OHM
- RS-02 RESISTOR 2K OHM
- RS-03 RESISTOR 4.02K OHM
- RS-04 RESISTOR 8.06K OHM
- RS-11 RESISTOR 10 OHM
- SD-01 SUPPLY AIR SMOKE DETECTOR (OPTIONAL)
- SD-02 RETURN AIR SMOKE DETECTOR (OPTIONAL)
- ST-01 MAIN SUPPLY FAN MOTOR STARTER
- SW-01 MAIN DISCONNECT SWITCH (OPTIONAL)
- SW-09 AUXILLARY UNIT ENABLE (BY OTHERS)
- SW-18 DAMPER MOTOR END SWITCH (OPTIONAL)
- SW-72 100 PERCENT OUTSIDE AIR SWITCH (BY OTHERS)
- TC-09 NIGHT SETBACK THERMOSTAT (OPTIONAL)
- TR-01 CONTROL CIRCUIT TRANSFORMER
- TR-05 LOW VOLTAGE TRANSFORMER
- TR-08 BURNER TRANSFORMER
- TS-01 OUTSIDE AIR TEMPERATURE SENSOR
- TS-02 SPACE TEMPERATURE SENSOR (OPTIONAL)
- TS-03 DISCHARGE AIR TEMPERATURE SENSOR
- UC-01 UNIT CONTROL MODULE
- VG-01 PILOT GAS VALVE
- VG-02 MAIN GAS VALVE

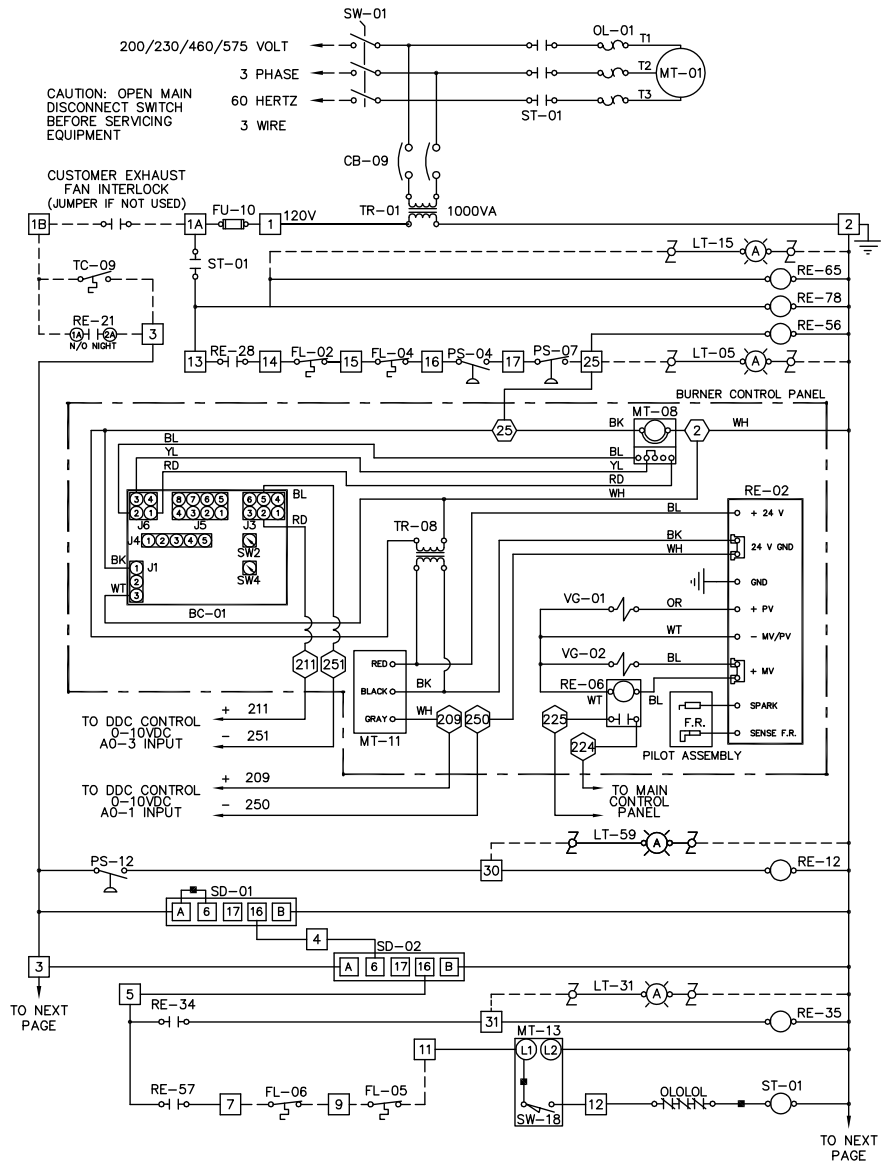

Typical Wiring

C000641C

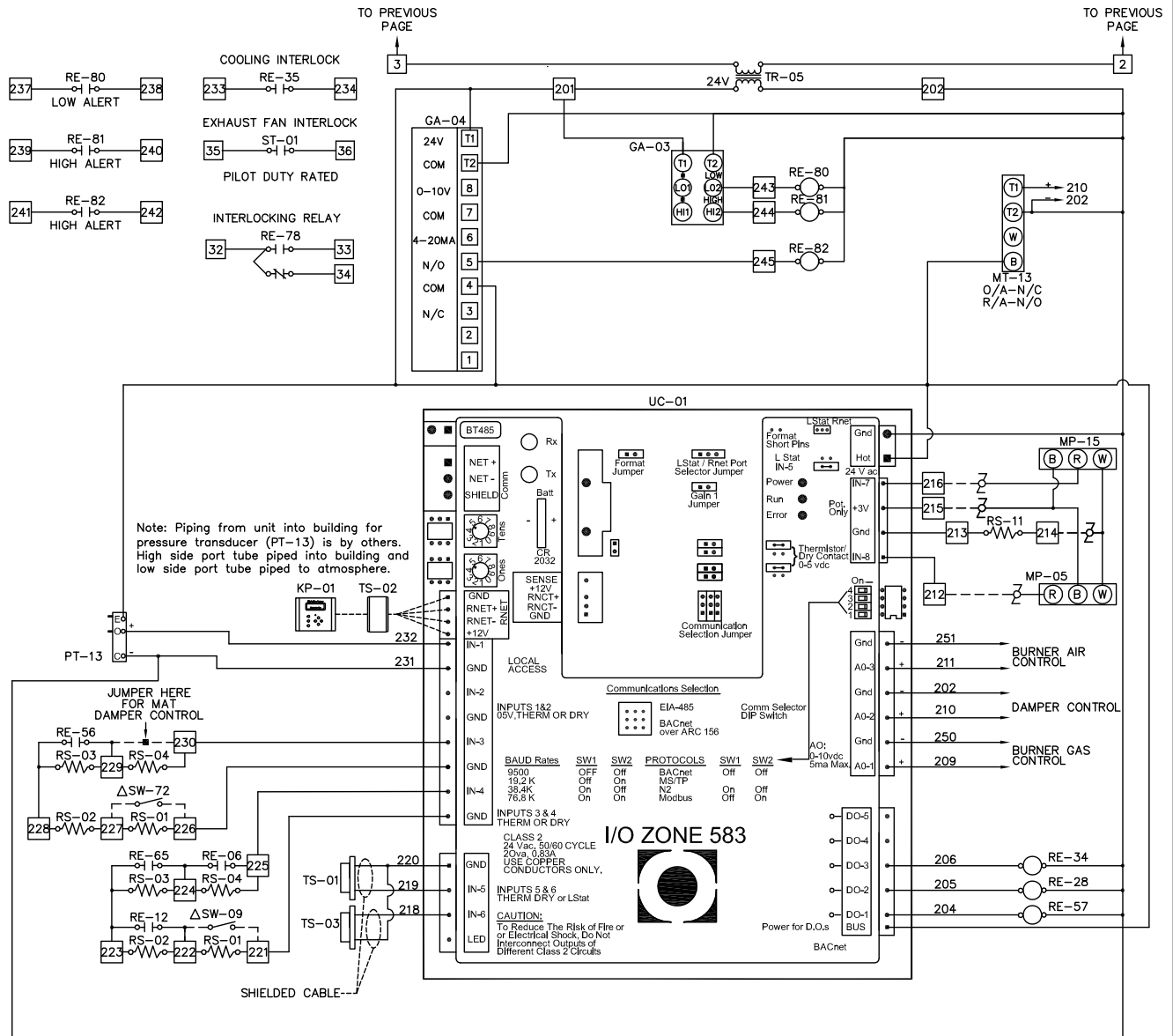

Amp Draw Table

Item A											
SOURCE	AMPS	MOTOR HORSEPOWER									
		1	1½	2	3	5	7½	10	15	20	25
Blower Motor	208V 3 Ph.	4.8	6.9	7.8	11.0	17.5	25.3	32.2	48.3	62.1	78.2
	230V 3 Ph.	4.2	6.0	6.8	9.6	15.3	22.0	28.8	42.0	54.0	68.0
	460V 3 Ph.	2.1	3.0	3.4	4.8	7.6	11.0	14.4	21.0	27.0	34.0
	575V 3 Ph.	1.7	2.4	2.7	3.9	6.1	9.0	11.5	17.0	22.0	27.0
Item B											
SOURCE	AMPS	BURNER MBH OUTPUT									
		160	320	480							
Blower Motor	208V 3 Ph.	5.00	5.00	5.00							
	230V 3 Ph.	4.35	4.35	4.35							
	460V 3 Ph.	2.17	2.17	2.17							
	575V 3 Ph.	1.74	1.74	1.74							

Steps to size optional disconnect switch

1. Find blower motor HP required from tables on pages 13-15.
2. Find amp draw for required motor HP in Item A above.
3. Determine proper burner size required.
4. Find amp draw for burner motor and control transformer Item B above.
5. Add amps from step 2 and step 4, multiply by 1.15.

Unit Weights

C000642A

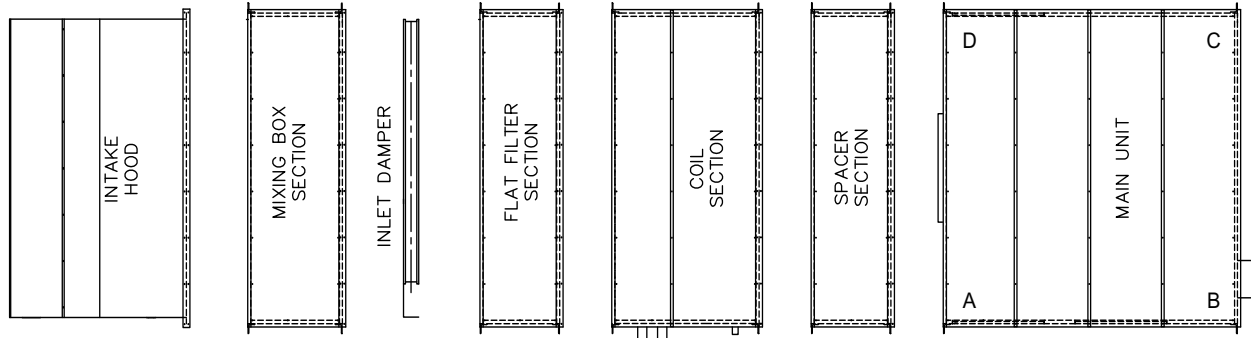

Model	Fan / Heat Exchanger Section				Spacer Section	Coil Section Note 1	Flat Filter Section Note 2	Mixing Box Section	Inlet Damper	Intake Hood
	A	B	C	D						
20	346	349	405	569	240	395	330	435	158	92
40	481	482	599	983	305	440	450	520	247	160
60	788	649	799	1378	360	540	560	630	367	265

NOTES:

- 1.) Coil section weight does not include coils. Add weight of selected coil from the coil performance chart. For two row reheat coil use 0.55 factor times weight of 4 row coil.
- 2.) Flat filter section weight includes 2" pleated filters and 12" deep 95 % efficient filters.

IFL Guide Specifications



Applied Air

Base Bid Applied Air Model IFL _____ Air handling unit(s) designed for rooftop outdoor applications. The unit shall be factory fabricated, assembled, wired and tested prior to shipment in accordance with the specification and equipment schedule. The unit will include all components herein and as shown on the drawings and as indicated on the equipment schedule. Alternate equipment, equal in design, construction, performance and capacity to unit(s) specified, must be shown with price deduct/add, if any. Approval of alternate equipment will be subject to review of shop drawings. The unit shall be capable of delivering _____ SCFM at _____ ESP using a _____ horsepower (ODP) (TEFC) motor operating on (208)(230)(460)(575)/3/60. The unit shall be ETL listed.

CASING

The unit shall be constructed from a formed supporting frame and panel type casing of 18 gauge galvanized steel, suitably reinforced to withstand 6" of TSP. All panels shall be factory sealed with caulking between mating panels. The base unit shall be of double wall construction with a 20 gauge galvanized steel inner liner to insure there is no exposed insulation. Radiation and transmission losses shall not exceed 1% of the rated output. The base unit shall be insulated with 1", 1-1/2 lb. density insulation.

The complete unit shall be weatherproof with up turned and caulked seams on the roof and floor. All electrical components shall be housed within the unit casing, separate add on enclosures are not acceptable.

The unit shall have an integral heavy gauge formed sheet metal base complete with curb adaptor frame for mounting on a full perimeter roof curb.

When split for shipping, the unit will incorporate heavy gauge internal gussets at top and specially designed lifting lugs at base to pull sections together. Discharge connection must be field convertible from end discharge to bottom discharge if required. Factory fabricated roof cap shall be shipped loose for field mounting over roof seam.

Access doors shall be supplied to allow physical entry to all sections requiring inspections and periodic maintenance. Access doors shall have lift off hinges (except blower section), 1" thick insulation, interior metal liner, captive screws, fasteners, and handles.

BLOWER SECTION

Each unit shall be supplied with single high efficiency plenum fan incorporating non-overloading backward airfoil wheel. The fan shall be tested in accordance with AMCA Standard 210 and bear the AMCA seal. The structural frame shall be of welded steel with "cross frame" bearing supports. The wheel shall be mounted on a heavy duty, turned and ground and polished solid steel shaft designed for a maximum operating speed not to exceed 70% of its first critical speed. The fan bearings are heavy-duty pillow block, self-aligning and pre-lubricated with minimum L10 bearing life of 40,000 hours.

Drives shall have a capacity 25% greater than the motor horsepower. The motor sheave shall be of the adjustable pitch type for motors up to 5 H.P.

The fan motor shall be mounted on an adjustable base and wired in flexible conduit to the control panel in the factory.

INDIRECT GAS FIRED SECTION

The entire primary and secondary heat transfer surface shall be of 400 series stainless steel. The heat exchanger design shall permit unrestricted lateral and peripheral expansion during the heating and cooling cycle. The flue gas travel shall be of two-pass design, with internal baffles in the secondary tubes. The surface temperature of the heat exchanger shall not exceed 75% of its scaling temperature when operating at rated capacity. The heat exchanger efficiency must exceed 80% throughout its complete operating range.

BURNER

The Digital High Turndown burner shall be of the modulating power type gas burner (pat. 2,709,802) with individually controlled variable speed combustion air blower motor and motorized gas valve for linkageless design. Burner shall be complete with observation window. The variable speed combustion air blower and motorized gas valve shall be independently controlled by the AdaptAire (pat. 7,059,536) control system to insure a proper gas/air mixture throughout the complete range of operation. Burner and controls shall be capable of delivering _____ MBH output on natural gas at an inlet pressure of _____ (inches water column) (PSIG). The standard ETL listed unit will meet ANSI, FM, and IRI requirements. Burner and controls shall be arranged for full modulation with a _____ turndown ratio. The factory wired and piped valve train shall be complete with:

- low pressure regulator
- motorized gas control valve
- main manual test firing shut-off valve (480 MBH output only)
- main automatic shut-off valve(s)
- pilot manual shut-off valve (480 MBH output only)
- pilot pressure regulator (480 MBH output only)
- pilot automatic shut-off valve (480 MBH output only)
- pilot manual test firing shut-off valve (480 MBH output only)

IFL Guide Specifications



Applied Air

ELECTRICAL CONTROLS

The unit weatherproof control enclosure shall be complete with hinged access door. All control components are to be labeled and individually wired to a numbered terminal strip to aid in servicing. All wiring shall be color coded and number tagged at each end to match the control diagram supplied. Full set of drawings, operating and maintenance instructions shall accompany each unit. All wiring between the controls and valves shall be run in flexible conduit. All electrical components shall bear the U.L. label. The control system shall include but not be limited to the following components required for automatic operation:

- control circuit transformer
- fan motor starters, overloads and sub-circuit fuses
- control circuit fuses
- control relays
- electronic flame relay
- high limit switch
- automatic/manual fan switch
- The unit shall be controlled by the AdaptAire (pat. 7,059,536) DDC control module with full BACnet compatibility. Unit shall have the AdaptAire (pat. 7,059,536) (MDT - Modulating Discharge Temperature Control System) (MRT— Modulating Room Temperature Control System) (MRT-Expert Modulating Room Expert Temperature Control System) (VDT-Expert Modulating Discharge Expert Temperature Control System). The AdaptAire (pat. 7,059,536) DDC control system shall include but not limited to the following controls required for standard operation:
 - Electronic time clock with normal, holiday, and override schedules. (Optional Accessory on MDT or MRT Control Systems).
 - Timed freeze protection to prevent heater from discharging unheated air into the building.
 - Heating Economizer which will turn burner off when inlet temperature equals desired discharge air temperature as fuel savings mode.
 - On-Off night setback thermostat for lower operating temperatures in unoccupied mode as fuel savings mode. (Optional Accessory on MDT or MRT Control Systems).
 - Two stage cooling controls.
 - Cooling Economizer which will turn cooling off when inlet temperature equals desired discharge air temperature as energy savings mode.
 - Optional keypad display and alarm indication.
 - Indicating lights for maintenance trouble shooting

OPTIONAL EQUIPMENT & CONTROLS

1. Motorized inlet air shut-off damper with blade and jamb seals. The damper and actuator shall be mounted inside the unit casing.
2. Flat Bank filter section with nominal 2" thick (filter racks only) (throwaway) (pleated) (cleanable) filters or nominal 2" thick pleated filters with (4" deep 65% efficient filters) (4" deep 95% efficient filters) (12" deep 95% efficient filters).
3. Cooling coil section complete with Flat Bank filter section with nominal 2" thick pleated filters. (Chilled Water) (DX) coil(s) with copper tubes, aluminum fins and galvanized steel casing. Headers to be non-ferrous with vents, drains and suitable for 700 psi working pressure. Maximum air velocity across the face of the coil shall not exceed 540 fpm. Cooling coil section shall have insulated casing. Coils to slide into unit through a removable end panel. Provide 304 stainless steel double sloped drain pan under the cooling coil and a minimum of 18" downstream of the coil to collect all condensation.
4. Inlet hood and birdscreen with maximum inlet velocity not to exceed 500 FPM.
5. Mixed air section with O/A and R/A parallel blade dampers with blade and jamb seals. Direct drive actuators mounted inside casing and set for full modulation control.
6. Perimeter roof curb.(12" high) (18" high)
7. Internal insulation 1", 1-1/2 lb density (filter section) (mixing section)
8. Extended lube lines
9. Internal blower/motor isolation (open spring) (seismic spring)
10. Double wall construction
11. Clogged filter switch with indication
12. Disconnect switch
13. Painted galvanized casing
14. High gas pressure regulator (shipped loose for inlet pressures over 1/2 PSIG).
15. Direct drive motor/blower assembly.
16. Variable Frequency Drive (VFD) for supply fan motor.



Applied Air

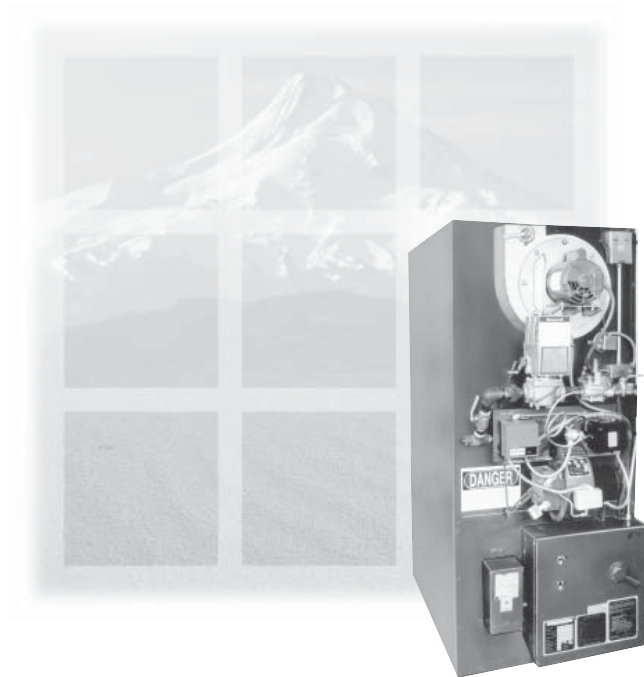

Efficient Indirect Fired Comfort Systems

Choose Applied Air Indirect Gas Fired Systems

- Heat large spaces or warehouses without products of combustion in the supply air
- Mount units indoor, outdoors, or on the roof
- Low operating and maintenance costs
- Simple, inexpensive installation
- Applied Air, a leader in research, engineering, and customer service since 1975

Applied Air

www.appliedair.com

4830 Transport Drive Dallas TX 75247

Telephone 214.638.6010

In the interest of product improvement Applied Air reserves the right to make changes without notice.